



OPERATOR'S MANUAL
MANUAL DEL OPERADOR
操作指南

En
E
繁

30-5SDK5
30-5SDK8
30-5SDK9
30-5SDK10
30-5SDK11



OPERATOR'S MANUAL

En (English)

MANUAL DEL OPERADOR

E (Español)

操作指南

繁 (繁体字)

CONTENTS

Note to Operators and Supervisors	2
Before Initial Operation	2
Caution Plates	3
Main Components	4
Driving Controls and Instrument Panel	4
Instruments	5
Switches and Controls	8
Operator's Seat and Frame	16
Correct Operation	16
Materials Handling Operations	25
Handling Vehicle in Cold Season	27
Handling Vehicle in Hot Season	31
Long Term Storage	32
Transportation	33
Pre-operation Check	33
Before Garaging the Vehicle	39
Weekly Maintenance	39
Self Service	42
Frame Serial Number	46
Fuel Tank Check	46
How to Read Name Plate	46
Lubrication Chart	47
Periodic Maintenance	48
Periodic Replacement Table	48
Periodic Maintenance Table	48
Service Data	51
Wheel & Tire	52
Vehicle Dimension	53

NOTE TO OPERATORS AND SUPERVISORS

This manual explains the proper operation and maintenance of Toyota industrial vehicles as well as daily lubrication and periodic inspection procedures.

Please read this manual thoroughly even though you may already be familiar with other Toyota industrial vehicles because it contains information which is exclusive to this series of vehicles. The manual has been produced based on a standard vehicle. However, if you have questions on other types, please contact your Toyota industrial vehicle dealer (Toyota dealer).

Toyota reserves the right to make any changes or modifications of specifications in this manual without giving previous notice and without incurring any obligation.

BEFORE INITIAL OPERATION

- Please read this manual thoroughly. This will give you a complete understanding of Toyota industrial vehicles and permit you to operate them correctly and safely. Proper handling of new vehicles promotes performance and extends service life. Drive with special caution while becoming familiar with a new vehicle. In addition to the standard operating procedures, pay attention to the following safety items.
- Please acquire thorough knowledge on Toyota industrial vehicle. Read the operator's manual thoroughly prior to operating the vehicle. Get to know its operation and components. Learn about the safety devices and accessory equipment and their limits and precautions. Be sure to read the caution plate attached to the vehicle.
- Please learn safe driving points and safety management. Understand and maintain working area traffic rules. Ask the work area supervisor about any special working precautions.
- Wear neat clothing for operation. Improper clothing for vehicle operation may interfere smooth operation and cause an unexpected accident. Always wear proper clothing for easy operation.
- Please keep away from live electric power lines. Know the locations of inside and outside power lines and maintain sufficient distance.
- Be sure to perform pre-operation check and periodic maintenance. This will prevent sudden malfunctions, improve work efficiency, save money and insure safe working conditions.
- Use only the recommended types of fuel and lubricants. Low-grade fuel and lubricants will shorten service life.
- Always warm up the engine before starting operation.
- If you hear any unusual noise or sense anything unusual, inspect and repair immediately.
- If the engine stops during traveling, the operation will be affected. Stop the vehicle in a safe place as described below. Operate the steering control lever more firmly than usual.
- When towing the vehicle. If a vehicle is no longer able to operate due to a breakdown, etc. and needs to be towed, the parking brake must be disengaged. Please ask a Toyota dealer for towing a broken down vehicle.
- Never attempt traveling when the bucket are elevated with a load beyond the specified height. Traveling with a load on the bucket elevated beyond the specified height may cause overturning due to the upward of gravity. Keep the bucket height at 15-20cm (6-8in) above the ground when traveling.
- Flammable and/or combustible materials can be damaged and in some cases ignited by a hot exhaust system or hot exhaust gases. To minimize the possibility for such damage or fire, the operator must obey the following recommended practices:
 - Do not operate the vehicle over or near flammable and/or combustible materials, including dried grass and paper scraps.
 - Park the vehicle with rear end at least 30cm (12in) away from lumber, veneer board, paper products and other similar materials to avoid discoloration, deformation or combustion of those materials.
 - Vertical arm (30-55DK10, 11) The bucket raises and lowers almost vertically. Since the lift arm moves toward the rear of the vehicle during material handling, particular attention should be paid to the rear of the vehicle during this operation.

Interlock system

The interlock system is a system that does not allow the vehicle to travel and perform material handling operations unless all of the following conditions are met:

- Ignition switch should be turned ON;
- Seat switch should be turned ON;
- Seat bar should be lowered into position;
- Operation switch should be turned ON.

⚠ Caution

If the interlock system activates during vehicle operation, the vehicle movement will stop. During operation, do not turn OFF the seat switch or the ignition switch and do not raise the seat bar.

Interlock system for traveling

When any of the following situations arise whilst the vehicle is in motion, the brake will engage and the vehicle will stop.

- When the ignition switch is turned OFF.
- When the seat bar is raised.
- When the parking brake disengagement switch is turned OFF.
- When the engine stalls.

Note:

- When the operation switch or the parking brake disengagement switch is turned OFF during traveling, the brake can be disengaged when the engine is started and the operation switch is turned ON again.
- When the ignition switch is turned OFF, the seat bar is raised or the engine stalls, after restoring the appropriate operational conditions, if the engine is started and the operation switch is turned ON again, the stopping status can be released.

Interlock system for material handling

When any of the following situations arise during material handling operations, this system will lock the material handling pedals (lift, dump) preventing material handling operations from being performed.

- When the ignition switch is turned OFF.
- When the seat bar is raised.
- When the operator leaves the seat and the seat switch is turned OFF.
- When the engine stalls.

Note:

When the material handling pedals (lift, dump) lock during material handling operations as a result of any of the above situations, after restoring the appropriate operational conditions, if the engine is started and the operation switch turned ON, the material handling pedals (lift, dump) lock can be released.

Interlock system for material handling

(Material handling hand control vehicle: Option)

When any of the following situations arise during material handling operations, this system will disable the lifting and dumping operations of the steering control levers preventing material handling operations from being performed.

- When the ignition switch is turned OFF.
- When the seat bar is raised.
- When the operator leaves the seat and the seat switch is turned OFF.
- When the engine stalls.

Note:

When the operations of the steering control levers become disabled as a result of any of the above situations, after restoring the appropriate operational conditions, if the engine is started and the operation switch turned ON, the lifting and dumping operations of the steering control levers can be enabled.

CAUTION PLATES

Caution plates are attached on a vehicle. Before driving it, please be sure to read them thoroughly. (The sample shows those of an English version.)

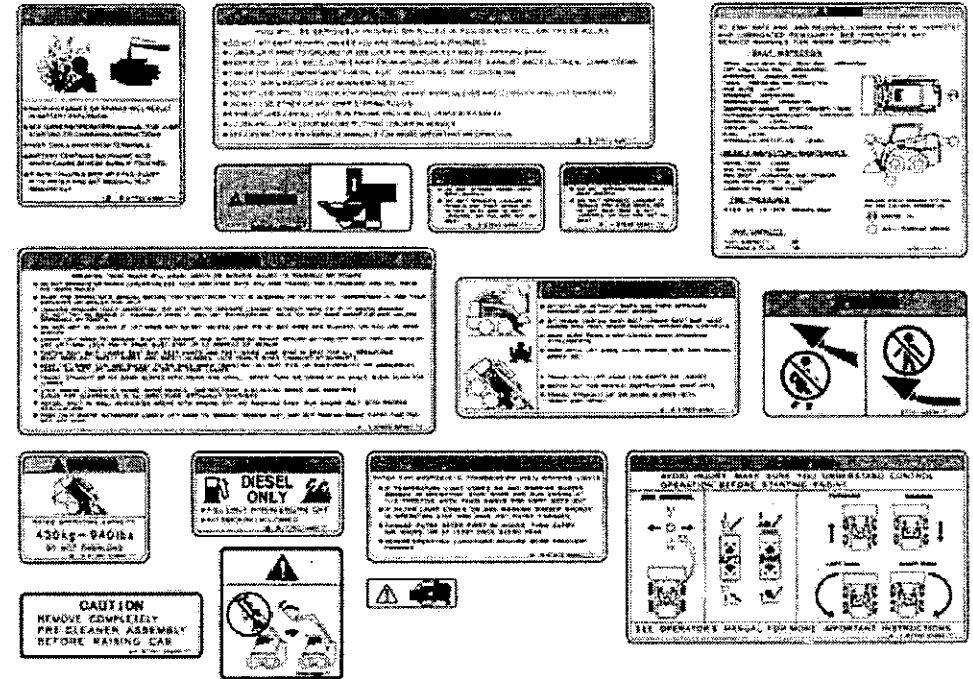

En

MAIN COMPONENTS

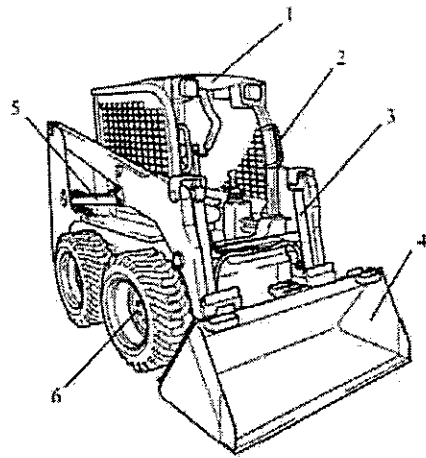

1. Operator guard
2. Assist grip
3. Dump cylinder
4. Bucket
5. Lift cylinder
6. Front wheel
7. Lift arm
8. Rear wheel
9. Engine hood
10. Rear grill

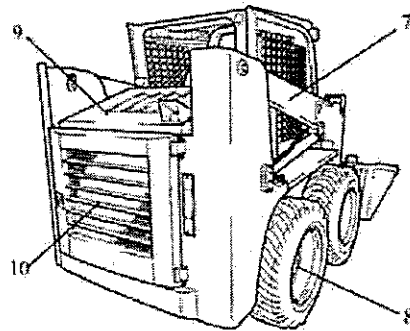

DRIVING CONTROLS AND INSTRUMENT PANEL

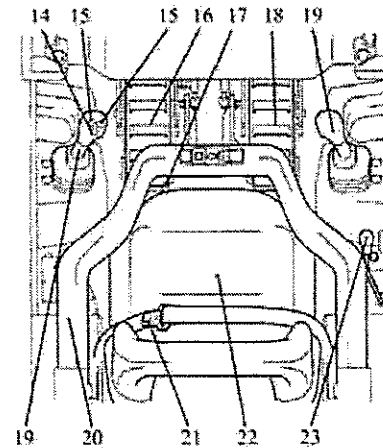
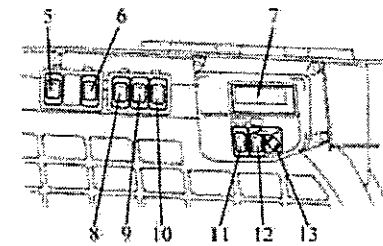
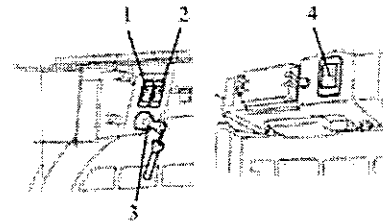

1. Head lamp switch
2. Working lamp switch (Option)
3. Ignition switch
4. Attachment detent switch
5. External hydraulic pressure supply switch
6. High flow switch (Option)
7. Combination meter
8. Front wiper switch (Option)
9. Heater switch (Option)
10. Yellow strobo lamp switch (Option)
11. Operation switch
12. Parking brake disengagement switch
13. Accessory socket
14. Horn switch
15. Turn signal switch
16. Lift pedal
17. Seat slide lever
18. Dump pedal
19. Steering control levers
20. Seat bar
21. Seat belt
22. Operator's seat
23. Accelerator lever

INSTRUMENTS

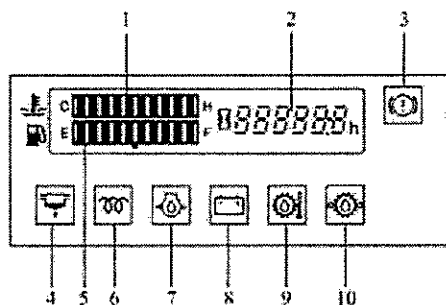

Combination meter

1. Water temperature gauge
2. Hour meter
3. Parking brake warning lamp
4. Sedimenter warning lamp
5. Fuel gauge
6. Glow indicator lamp
(3TNV88, 1DZ-II engine models)
7. Preheating indicator lamp
(2Z engine models)
8. Engine oil pressure warning lamp
9. Charge warning lamp
10. HST oil temperature warning lamp
10. HST oil filter warning lamp



Water temperature gauge

Indicates the temperature of the engine coolant.

1. This gauge functions with the ignition switch ON, and displays the coolant water temperature from left to right in a 10-stage gradation scale.
2. The operator will be notified when the water temperature is 95°C or over (above 8th stage), as the final two stages at far right begin blinking. Again, when the engine protection function activates, the entire gauge will start blinking to inform the operator.
3. Temporary overheating may be caused by coolant leakage, low engine coolant level, loosened fan belt, or other problem in the cooling system. Contact your Toyota dealer to request an inspection.

En

Hour meter

The hour meter operates when the ignition switch is turned to ON. It indicates the total number of vehicle operating hours.

The unit of the right most digit is 1/10 hour. Please use this meter for the timing of periodic maintenance and recording the operation hours.



Each warning lamp check method

Please check if all warning lamps come on when the ignition switch is turned to ON.

Note:

Use the light control switch to check the meter-lighting lamp.

⚠ Caution

- The glow indicator lamp is only on for 2 seconds when the engine coolant temperature exceeds 50°C.
- If a lamp does not light up, contact your Toyota dealer to request an inspection.

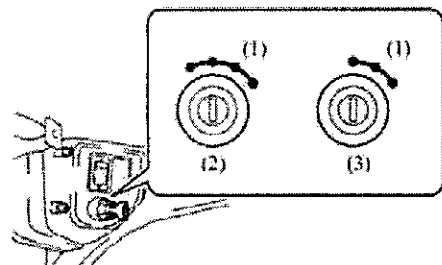

- (1) ON
- (2) 3TNV88 engine models
- (3) 1DZ-II, 2Z engine models



Parking brake warning lamp

When the parking brake is engaged, the warning lamp will light up to notify the operator. The warning lamp will light up when the parking brake is engaged. After disengaging the brake to operate the vehicle, check to make sure the warning lamp has turned off.

Caution

If the lamp does not go off even when the parking brake disengagement switch is turned into the OFF position, contact your Toyota dealer to request an inspection.

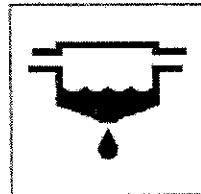

Sediment warning lamp

The sedimenter is a device for separating water from the fuel.

1. The warning lamp comes on to indicate water in the sedimenter exceeds the predetermined level while the engine is running.
2. If normal, the lamp comes on when the ignition switch is turned to ON and goes off when the engine starts.
3. If the lamp comes on while the engine is running, drain water immediately. (See the self service section for the draining instructions.)

Caution

Continued operation with the lamp on may cause seizure of the injection pump and pump damage. If the warning lamp lights up, always make sure to drain the water.



Fuel gauge

Indicates the amount of remaining fuel in the fuel tank in terms of a 10-stage gradation scale. The operator will be notified that remaining fuel level is low when the two stages at far left start blinking.

It takes some time for the indication to be stabilized after refuelling and the ignition switch is turned to ON.

Note:

- If the operating area is not level, attention must be paid because the correct level may not be indicated.
- When the gauge begins blinking, refuel as soon as possible.
- In case of diesel engine, be sure to refuel it before it runs out because when this occurs it becomes necessary to bleed air from the fuel supply system.

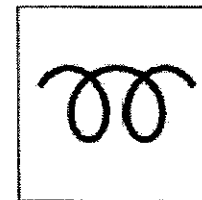

Glow indicator lamp (3TNV88, 1DZ-II engine models)

Indicates heating of glow plugs.

When the ignition switch is turned to GLOW, the lamp comes on and glow plug heating begins. The lamp goes off automatically when glow plug heating is complete. The engine will start easily once the glow plugs are heated.

Note:

The glow indicator lamp is on for 2 seconds when the engine coolant temperature exceeds 50°C.

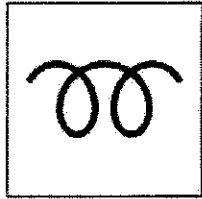

Preheating indicator lamp (2Z engine models)

Indicates preheating of the intake heater.

1. When the ignition switch is turned ON, the lamp comes on and preheating starts. The lamp goes off automatically when preheating is complete. The engine will start easily.

Note:

When the engine coolant temperature exceeds 2.5°C, this lamp does not come on because preheating is not carried out.

2. The length of preheating time is automatically controlled according to the engine coolant temperature. It gets somewhat longer when the engine coolant temperature is low or in a cold season.

⚠ Caution

If the indicator lamp does not go off if it comes on during engine running, the preheating intake heater may be defective. Please ask a Toyota dealer for inspection and repair.

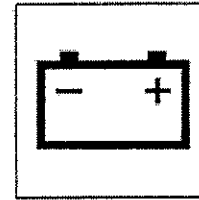

Charge warning lamp

1. This lamp comes on to indicate an abnormality in the charging system while the engine is running.
2. If normal, the lamp comes on when the ignition switch is turned to ON and goes off when the engine starts.

⚠ Caution

- If the lamp comes on while the engine is running, stop immediately, park the vehicle in a safe location, stop the engine and after the engine has cooled down inspect the fan belt for cuts or looseness, adjust it, and restart the engine.
- If lamp does not go off, the electrical system may be faulty. Please ask a Toyota dealer immediately for inspection and repair.

En

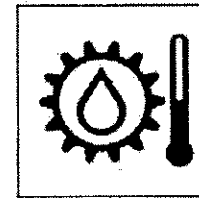

HST oil temperature warning lamp

While the engine is running, if the HST (Hydraulic Static Transmission) hydraulic oil temperature rises, the warning lamp comes on to warn the operator.

In normal conditions, the lamp comes on when the ignition switch is turned ON and goes off when the engine starts.

⚠ Caution

- If the warning lamp should come on while the engine is running, stop driving and run the engine at a speed slightly faster than idling speed, and allow the hydraulic oil to cool until the lamp goes off.
- If the hydraulic oil temperature reaches 85°C while performing material handling and attachment operations or while traveling, the heat protection function will activate a warning buzzer to warn the operator. Additionally, on vehicles with Australian specifications, if the hydraulic oil temperature reaches 100°C while performing material handling and attachment operations or while traveling, the material handling operation will stop. If the warning buzzer should sound, stop driving and run the engine at a speed slightly faster than idling speed, and allow the hydraulic oil to cool.

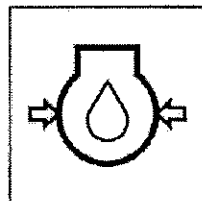

Engine oil pressure warning lamp

Comes on to indicate low engine oil pressure while the engine is running.

1. If normal, the lamp comes on when the ignition switch is turned to ON and goes off when the engine starts.
2. If the lamp comes on while the engine is running, either the engine oil is low or the lubrication system is faulty. Stop the operation immediately and ask a Toyota dealer for inspection and repair.

Note:

The "engine oil pressure warning lamp" does not indicate the oil level. Check the oil level using the oil level gauge before starting work.

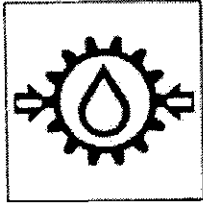

HST oil filter warning lamp

If the HST oil filter becomes clogged, a red lamp lights to warn the operator. This lamp also lights when the ignition switch is turned to the ON position, but goes off again when the engine starts. When the lamp comes on, immediately stop operation, and replace the HST oil filter. Never continue to operate the vehicle after the lamp has come on, or an HST breakdown may occur.

Note:

There is nothing unusual if the lamp comes on when the engine runs slowly but goes out with the engine speed increased.

SWITCHES AND LEVERS

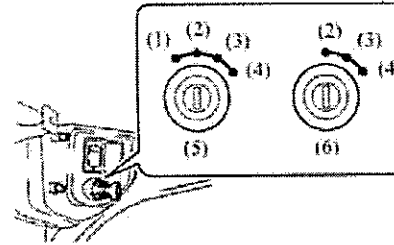

- (1) GLOW
- (2) OFF
- (3) ON
- (4) START
- (5) 3TNV88, 1DZ-II engine models
- (6) 2Z engine models

⚠ Caution

- Never operate the ignition switch without first sitting on the seat. Otherwise, the vehicle could start to move uncontrolled, causing an accident.
- Do not leave the switch in the ON position when the engine is stopped. Leave the switch in the ON position during engine operation.
- Do not turn the switch to the START position while the engine is running. This may damage the starter motor.

Ignition switch

The ignition key is inserted with the teeth facing upward.

- OFF** Engine stop position. Key inserting and withdrawal is performed in this position.
- ON** Engine operation position. Located one position clockwise from the OFF position. When the engine is started, the intake heater will heat up. (2Z engine models)
- START** Engine start position. Located one position clockwise from the ON position. After engine start, release the key and it will return to the ON position automatically.
- GLOW** Intake heater operating position. When the engine is in cold state, the air in the intake manifold is preheated by the glow plug. Turn the ignition switch counter clockwise from the OFF position. The engine can easily be started when the preheating indicator lamp goes off. (3TNV88, 1DZ-II engine models)

After engine start, release the key and it will return to the [ON] position automatically.

- Do not hold the switch in the START position for more than 15 seconds. Return the switch to the OFF position and wait at least 30 seconds prior to attempting restart.
- In case of the anti-restart ignition switch (optionally available), be sure to shift the switch to the [OFF] position before attempt to start the engine again.

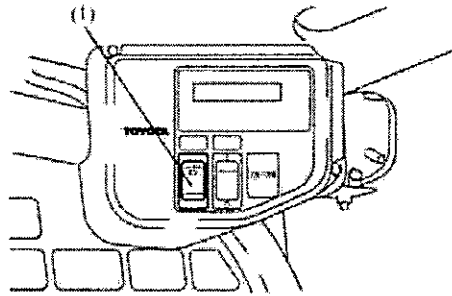

(1) Operation switch

Operation switch

When this switch is turned ON, traveling and material handling operations can be started. Also, when the switch is turned ON, the LED lamp comes on to notify the operator that the vehicle is operating.

Note:

With the interlock system, if the operator does not sit in the seat properly, if the operator does not lower the seat bar correctly, if the ignition switch is not turned ON, if the operation switch is not turned ON, if the parking brake disengagement switch is not turned ON, traveling and material handling operations cannot be performed.

⚠ Caution

Make sure that the interlock system is operating when leaving the vehicle.

Parking brake disengagement switch

When this switch is turned ON, the parking brake can be disengaged.

Note:

With the interlock system, if the operator does not sit in the seat properly, if the operator does not lower the seat bar correctly, if the ignition switch is not turned ON, if the operation switch is not turned ON, if the parking brake disengagement switch is not turned ON, traveling and material handling operations cannot be performed.

⚠ Caution

When leaving the vehicle, make sure to turn the parking brake disengagement switch OFF and make sure that the parking brake is operating.

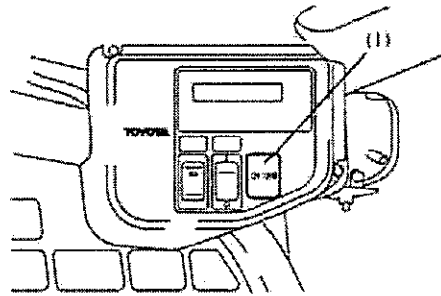

(1) Accessory socket

Accessory socket

This socket can provide a power supply when the ignition switch is turned ON.

⚠ Caution

Do not use in places subject to large amounts of dust. Dust could build up inside the accessory socket, causing malfunctions and/or faults.

Note:

- Equipment up to 120W (10A) may be used.
- Use the socket with the engine in start condition. If the socket is used with only the ignition switch turned ON, the battery will run flat, and as a result the engine may not start.

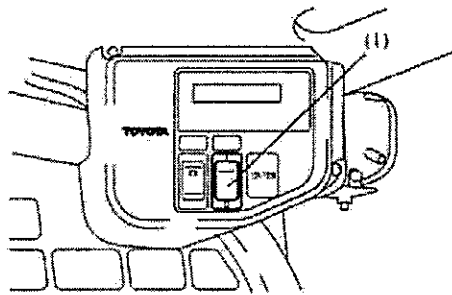

(1) Parking brake disengagement switch

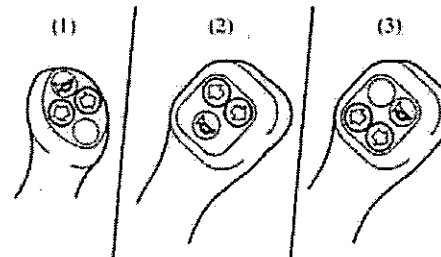

- (1) 30-SSDK5
- (2) 30-SSDK8, 9, 10, 11
- (3) 30-SSDK8, 9, 10, 11 (Option)

Turn signal switch (Option)

The turn signals blink to indicate the direction to which the vehicle is to turn.

Left turn Push the switch to left.

Right turn Push the switch to right.

This switch functions even with the ignition switch OFF.

Note:

The turn signal blinks while the switch is pressed.

En

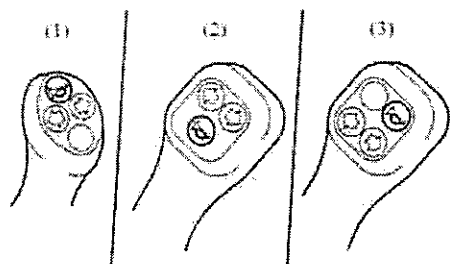

- (1) 30-SSDK5
- (2) 30-SSDK8, 9, 10, 11
- (3) 30-SSDK8, 9, 10, 11 (Option)

Horn switch

The horn is sounded by pushing the switch at the tip of steering control lever (at left side). The horn can be sounded even with the ignition switch OFF.

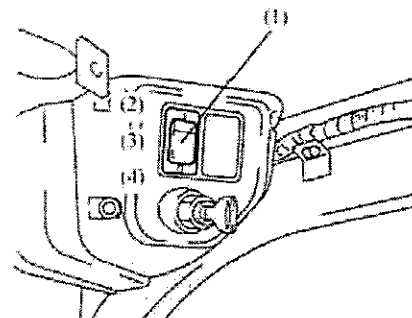

- (1) Head lamp switch
- (2) ON
- (3) Center ON
- (4) OFF

Head lamp switch

This is a 3-step type switch. The lamps which come on for each position of the switch are marked by a circle symbol in the table below.

	OFF	Center ON	ON
Head lamp	-	-	○
Side clearance lamp (Option), tail lamp (Option)	-	○	○

⚠ Caution

Do not keep the head lamp and other lamps on for a long time when the engine is not running.

It may consume the battery charge, resulting in failure in engine starting.

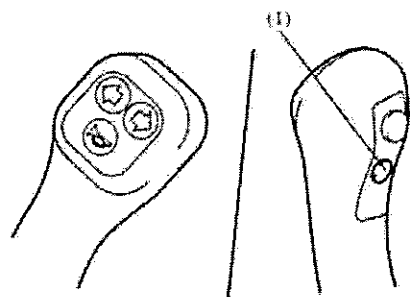

- (1) Ride control switch

Ride control switch (Option)

While this switch is held down, the lift arm vibration is held under control and the vehicle can travel safely when carrying heavy loads.

⚠ Caution

Do not operate this switch during material handling operations.

Note:

- When the switch is turned ON, the arm may move slightly.
- The arm moves upward and downward in proportion to the weight of load and road surface vibration.
- While the switch is held down, the leveling function does not operate.

- (2) Ride control switch (Material handling hand control vehicle: Option)

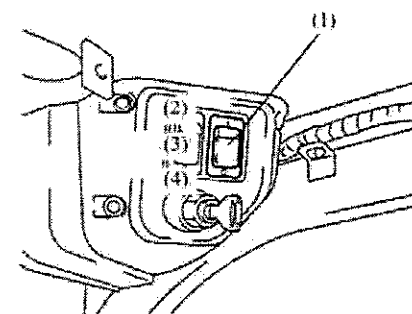

- (1) Working lamp switch
- (2) ON
- (3) OFF
- (4) BACK ON

Working lamp switch

When this switch is turned ON, the rear operation lamp is always on. If it is turned into the BACK ON position, the lamp will light up only when the vehicle is moving backwards.

Also, when the switch is turned ON, the LED lamp comes on to notify the operator that the rear operation lamp is on.

⚠ Caution

Do not keep the working lamp and other lamps on for a long time when the engine is not running.

It may consume the battery charge, resulting in failure in engine starting.

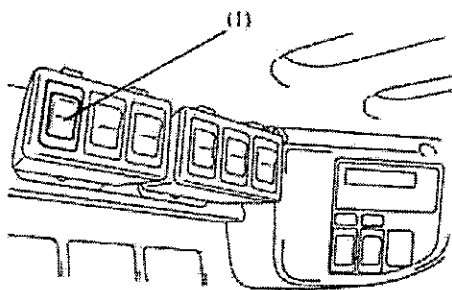

(1) External hydraulic pressure supply switch

External hydraulic pressure supply switch

When this switch is turned ON, the vehicle with an attachment installed can be used as a power unit.

Also, when the switch is turned ON, the LED lamp comes on to notify the operator that external hydraulic pressure can be supplied.

Note:

When the seat bar is raised and the switch is turned ON, the vehicle enters the external hydraulic pressure supply status, therefore it cannot travel or perform material handling operations.

⚠ Caution

- Turn ON the external hydraulic pressure supply switch after making sure that the bucket has been grounded and that the operation switch and the parking brake disengagement switch are turned OFF.
- Since oil can be conveyed oil from the attachment pipe even when the driver is not in the driving seat, please pay attention when climbing in and out of the vehicle.

Operation

(Standard vehicle)

1. Firmly raise the seat bar.
2. Turn ON the external hydraulic pressure supply switch.
(At this time the LED lamp comes on.)
3. Operate the steering control lever (at right side) towards the left.

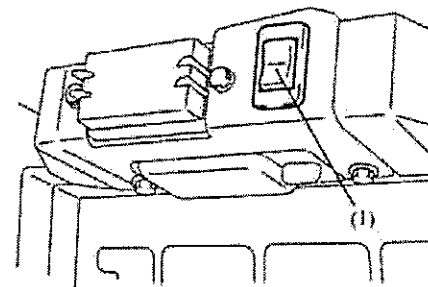

(1) Attachment detent switch

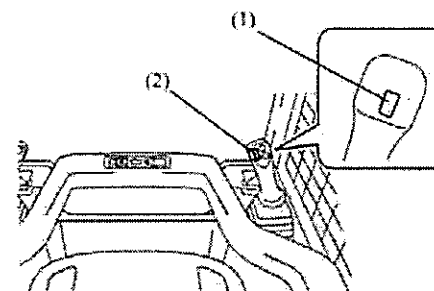

(1) Attachment output maintenance switch

(2) Attachment operation switch

4. If oil conveying should be maintained, press the attachment detent switch to move the steering control lever (at right side) fully towards the left.
(The lever will remain in this position.)
5. If oil conveying should be stopped, return the steering control lever (at right side) to the center position or turn OFF the attachment detent switch.
(When the attachment detent switch is turned OFF, the lever will automatically return to the center position.)

En

Operation

(Material handling hand control vehicle: Option)

1. Firmly raise the seat bar.
2. Turn ON the external hydraulic pressure supply switch.
(At this time the LED lamp comes on.)

Note:

When the external hydraulic pressure supply switch is turned ON, the attachment operation switch will be disabled.

3. When the attachment output maintenance switch is pressed, oil conveying starts and will be maintained.
4. To stop oil conveying, press the attachment output maintenance switch again.

⚠ Caution

When any of the following situations arise, the external hydraulic pressure supply status will be released and the LED lamp will go off.

- When the external hydraulic pressure supply switch is turned OFF.
- When the seat bar is lowered.
- When the ignition switch is turned OFF.

When the external hydraulic pressure supply status is released as a result of any of the above situations, after restoring the appropriate operational conditions, perform the steps again.

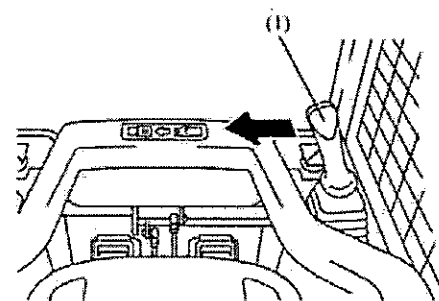

(1) Steering control lever

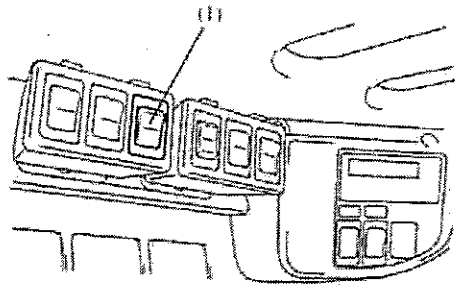

(1) High flow switch

High flow switch (Option)

When this switch is pressed, an attachment which needs a high flow rate may be used. If the high flow switch is pressed and the attachment operation switch is pressed, oil conveying will begin from the high flow pump after approximately 1.5 seconds.

Note:

- When the attachment operation switch is turned OFF, oil conveying stops.
- To disable high flow, press the high flow switch again.

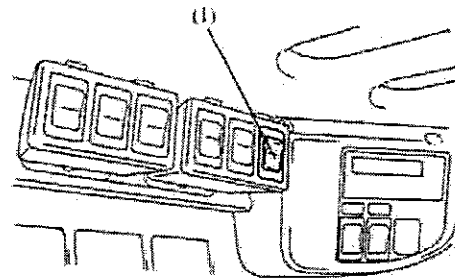

(1) Yellow strobo lamp switch

Yellow strobo lamp switch (Option)

When this switch is turned ON, the yellow strobo lamp is always on, if it is turned into the BACK ON position, the lamp will light up on only when the vehicle is moving backwards.

⚠ Caution

Do not keep the yellow strobo lamp and other lamps on for a long time when the engine is not running. It may consume the battery charge, resulting in failure in engine starting.

Cabin light switch (Option)

The cabin light switch is located on the rear left side of the operator guard. When the switch is turned into the ON position, the cabin light comes on, and when the switch is turned into the OFF position, the cabin light goes off.

Note:

Since the cabin light is not connected to the door, even when the switch is turned into the DOOR position, the light will not come on.

⚠ Caution

Do not keep the cabin light on for a long time when the engine is not running. The battery will run flat, and as a result the engine may not start.

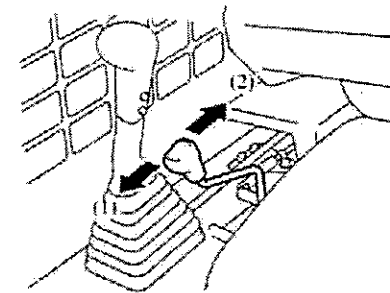

1. Maximum speed
2. Idling speed

Accelerator lever

This is the lever to adjust the engine speed. The desired engine speed is obtained by operation of this lever from idling to the maximum.

Idling speed Pull the lever backward.

Maximum speed Push the lever forward.

Set the lever slightly over the idling speed to start the engine. When the engine has been warmed up and the operation is to be started, push the lever to increase the speed and keep it constant during the operation.

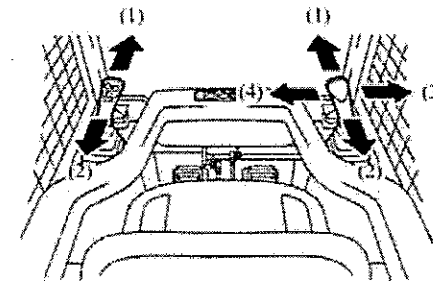

- (1) Forward
- (2) Backward
- (3) Detent on (for attachment)
- (4) Detent off (for attachment)

Steering control levers

These are the levers for steering operation (setting the wheel rotational direction) and speed control.

Forward Operate the lever forward.

Backward Operate the lever backward.

The speed is adjusted by the degree of lever operation. Refer to the section on "Operation" for detail.

⚠ Caution

- Since the steering control lever (at right side) also serves as the material handling control lever for the 3-levers attachment, it moves to the left and to the right.
- Always set the attachment lever detent to off when not operating the attachment.
Detent on Operate the lever outward.
Detent off Operate the lever inward.

Note:

- To turn the vehicle, pull backward the lever at the side to which the vehicle is to be turned, and push forward the lever at the other side.
- With the interlock system for traveling, if the operator does not sit in the seat properly, if the operator does not lower the seat bar correctly, if the ignition switch is not turned ON, if the operation switch is not turned ON, if the parking brake disengagement switch is not turned ON, traveling operation cannot be performed.

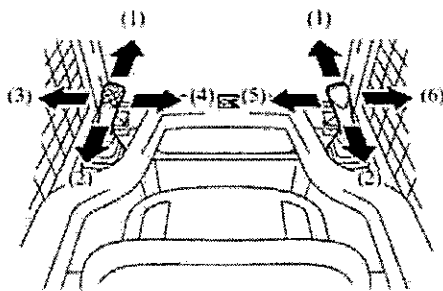

- (1) Forward
- (2) Backward
- (3) Up
- (4) Down
- (5) Backward tilt
- (6) Forward tilt

Steering control levers

These levers perform steering operations, speed control, and bucket raising/lowering and forward/backward tilting.

- Forward** Operate the lever forward.
- Backward**..... Operate the lever backward.
- Up** Operate the lever (at left side) outward.
- Down** Operate the lever (at left side) inward.
- Forward tilt** Operate the lever (at right side) outward.
- Backward tilt**.... Operate the lever (at right side) inward.

The speed is adjusted by the degree of lever operation. Refer to the section on "Operation" for detail.

Notes:

- As on material handling hand control vehicles (Option) the steering control levers perform all of the operations, there is no material handling pedals (lift, dump) setting.
- To turn the vehicle, pull backward the lever at the side to which the vehicle is to be turned, and push forward the lever at the other side.
- With the interlock system for traveling, if the operator does not sit in the seat properly, if the operator does not lower the seat bar correctly, if the ignition switch is not turned ON, if the operation switch is not turned ON, if the parking brake disengagement switch is not turned ON, traveling operation cannot be performed.
- With the hydraulic self-leveling function, the bucket angle will be maintained during lift arm raising.
- With the lift cylinder shockless function, before the lift arm reaches its fully lowered position (stroke end), the arm lowering speed will decrease.
The shockless function effects vary depending on the oil temperature and weight of load, and the weight of the installed attachment.

⚠ Caution

- When traveling, raise the bucket about 15-20cm (6-8in) from the ground.
- When traveling, fully tilt the bucket backwards and pull back the lift arm as much as possible.
- Bucket leveling may not occur if only a small degree of tilting is applied to the steering control lever (at left side) or the engine revs are low.
- When the arm is raised, if the steering control lever (at right side) is moved towards the left, the bucket will tilt backwards and the bucket contents will spill out. Therefore, in order to avoid the bucket tilting backwards, do not move the steering control lever (at right side) towards backward tilt.
- When leaving the seat, make sure that all of the levers have been returned to the center position.

En

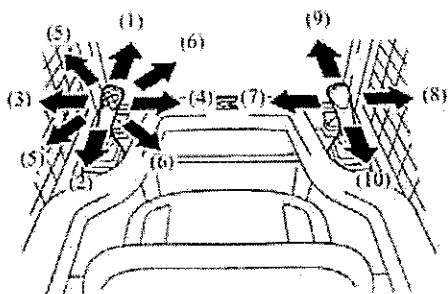

- (1) Forward
- (2) Backward
- (3) Left pivot turn
- (4) Right pivot turn
- (5) Left turn
- (6) Right turn
- (7) Backward tilt
- (8) Forward tilt
- (9) Down
- (10) Up

Steering control levers (Option)

These levers perform steering operations, speed control, and bucket raising/lowering and forward/backward tilting.

- Forward Operate the lever (at left side) forward.
- Backward..... Operate the lever (at left side) backward.
- Left pivot turn..... Operate the lever (at left side) outward.
- Right pivot turn Operate the lever (at left side) inward.
- Left turn Operate the lever (at left side) diagonally forward to left or diagonally backward to left.
- Right turn Operate the lever (at left side) diagonally forward to right or diagonally backward to right.
- Forward tilt Operate the lever (at right side) outward.
- Backward tilt..... Operate the lever (at right side) inward.
- Up Operate the lever (at left side) backward.
- Down Operate the lever (at left side) forward.

The speed is adjusted by the degree of lever operation. Refer to the section on "Operation" for detail.

Note:

- As on material handling hand control vehicles (Option) the steering control levers perform all of the operations, there is no material handling pedals (lift, dump) setting.
- With the interlock system for traveling, if the operator does not sit in the seat properly, if the operator does not lower the seat bar correctly, if the ignition switch is not turned ON, if the operation switch is not turned ON, if the parking brake disengagement switch is not turned ON, traveling operation cannot be performed.
- With the hydraulic pressure self-leveling function, the bucket angle will be maintained during lift arm raising.
- With the lift cylinder shockless function, before the lift arm reaches its fully lowered position (stroke end), the arm lowering speed will decrease. The shockless function effects vary depending on the oil temperature and weight of load, and the weight of the installed attachment.

⚠ Caution

- When traveling, raise the bucket about 15-20cm (6-8in) from the ground.
- When traveling, fully tilt the bucket backwards and pull back the lift arm as much as possible.
- Bucket leveling may not occur if only a small degree of tilting is applied to the steering control lever (at left side) or the engine revs are low.
- When the arm is raised, if the steering control lever (at right side) is moved towards the left, the bucket will tilt backwards and the bucket contents will spill out. Therefore, in order to avoid the bucket tilting backwards, do not move the steering control lever (at right side) towards the left.
- When leaving the seat, make sure that all of the levers have been returned to the center position.

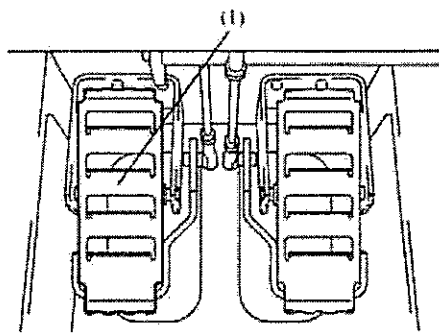

(1) Lift pedal

Lift pedal

This pedal controls the hydraulic lifting system of the bucket for material handling.

- Up Depress the rear side of the pedal.
 Down Depress the front side of the pedal.

The speed is adjusted both for lifting up and lowering by the engine speed (accelerator lever operation) and the degree of the pedal depressing. Press the front part of the pedal fully to the floor from the descending stage. Then the pedal will come to be fixed shifting into the floating stage, moving the lift arm into a floating status. To release the lift arm from the floating status, press the rear part of the pedal fully to the floor.

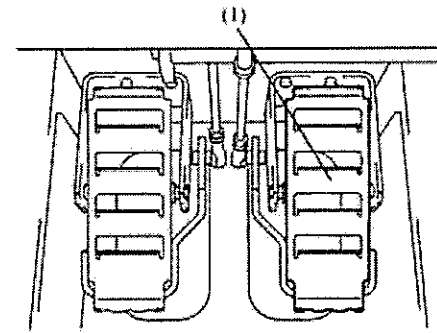

(1) Dump pedal

Dump pedal

This is the pedal to tilt the bucket forward or backward.

- Forward tilt Depress the front side of the pedal.
 Backward tilt Depress the rear side of the pedal.

The speed is adjusted both for forward and backward tilt by the engine speed (the accelerator lever operation) and the degree of the pedal depressing.

⚠ Caution

- When traveling, raise the bucket about 15-20cm (6-8in) from the ground.
- When traveling, fully tilt the bucket backwards and pull back the lift arm as much as possible.
- Bucket leveling may not occur if only a small degree of depressure is applied to the pedals or the engine revs are low.
- When the arm is raised, if the pedal is depressed for backward tilt, the bucket will tilt backwards and the bucket contents will spill out. Therefore, in order to avoid the bucket tilting backwards, do not depress the pedal for backward tilt.
- When leaving the seat, make sure that all of the levers have been returned to the center position.

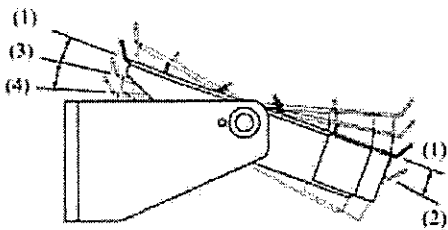

- (1) Neutral
 (2) Upward
 (3) Downward
 (4) Float

Leveling device

Since pressure leveling controls the oil returning to the lift cylinder through the valve, if the level of the returning oil is insufficient, the valve may not operate.

For this reason, leveling may not occur if the pressure on the lift pedal is light, or the engine speed is low.

Take care when using the dump pedal. If the rear end of the dump pedal is pressed when the lift arm is raised, the bucket will tilt backwards and the bucket contents will shift to the back of the bucket.

⚠ Caution

- Always bring the lift arm to its lowest position before shifting into or out of the floating stage.
- When leaving the driver's seat, always make sure that the pedal is in neutral position.

Note:

- Each material handling pedal is designed so that it can not be operated unless the operator sits on the operator's seat, lowers the seat bar, and turns the ignition switch to the ON position.
- With the hydraulic self-leveling function, the bucket angle will be maintained during lift arm raising.

OPERATOR'S SEAT AND FRAME

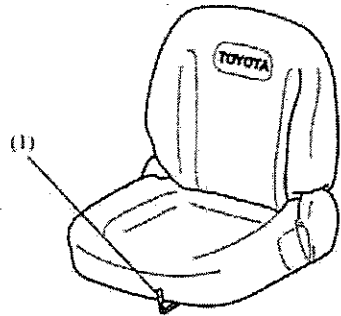

(1) Seat slide lever

Operator's seat

⚠ Warning

Do not place your arms, head or body outside the operator guard.

The operator's seat and seat belt are provided for your safety.

The seat can be moved back and forth for position adjustment while the seat slide lever is pulled upward.

⚠ Caution

- To prevent accidents, make sure to check the seat adjustment before driving.
- To prevent accidents, do not perform seat adjustments while traveling.
- Adjust the seat position so that all of the pedals can be properly depressed when sitting in the operator's seat leaning against the seat back.
- With the interlock system, if the operator is not sitting down in the seat properly, traveling and material handling operations cannot be performed. Perform each operation sitting in the seat correctly. Additionally, do not perform any operation when something is on the seat.
- After adjustment, lightly shake the seat forward and backward to confirm that the seat is firmly locked in position.

Note:

Do not turn ON the seat switch to perform operations when not sitting in the seat. If the seat switch is turned OFF for 1 second when the operation switch is turned ON, the material handling pedals (lift, dump) will be locked and the material handling operations will be inhibited. At this point, if the operator sits down again correctly, only the traveling operation will be enabled. To restart the material handling operation, turn ON the operation switch again.

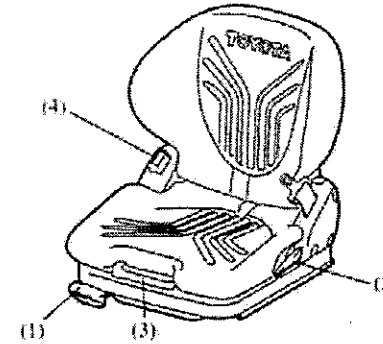

- (1) Seat slide lever
- (2) Recliner adjust lever
- (3) Weight adjust knob
- (4) Seat belt

Note:

Do not turn ON the seat switch to perform operations when not sitting in the seat. If the seat switch is turned OFF for 1 second when the operation switch is turned ON, the material handling pedals (lift, dump) will be locked and the material handling operations will be inhibited. At this point, if the operator sits down again correctly, only the traveling operation will be enabled. To restart the material handling operation, turn ON the operation switch again.

Suspension seat (Option)

⚠ Warning

- Do not place your arms, head or body outside the operator guard.
- For vehicles with suspension seat specifications, if your feet are touching the front edge of the seat, the seat switch may determine this to mean that "the operator is seated"

The seat suspension mechanism provides a comfortable seating position according to the weight of the driver. The optimum driving position can be set using the knob and levers.

Seat slide lever

Lift the slide lever to adjust the back-and-forth position of the seat. The seat is secured in position when you release the lever.

Recliner adjust lever

Pull the lever on the left to adjust the seat's angle of recline.

Weight adjust knob

Pull the adjust knob towards you and move it up and down until the orange indicator is in the center. Adjustment can be made for body weights between 45 kg and 170 kg.

⚠ Caution

- To prevent accidents, make sure to check the seat adjustment before driving.
- To prevent accidents, do not perform seat adjustments while traveling.
- Adjust the seat position so that all of the pedals can be properly depressed when sitting in the operator's seat leaning against the seat back.
- With the interlock system, if the operator is not sitting down in the seat properly, traveling and material handling operations cannot be performed. Perform each operation sitting in the seat correctly. Additionally, do not perform any operation when something is on the seat.
- After adjustment, lightly shake the seat forward and backward to confirm that the seat is firmly locked in position.

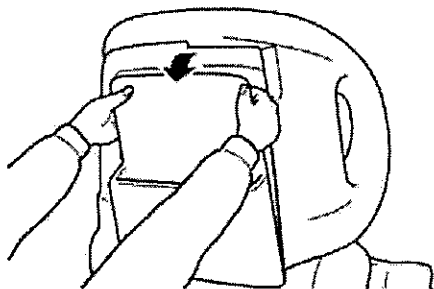

Pocket

An operator's manual are located on the rear side of the seat. Make sure to open the seat back pocket with both hands. If your vehicle does not have an operator's manual, please contact (your authorized Toyota dealer) to obtain copies for your vehicle.

Note:

Make sure the pocket is closed securely.

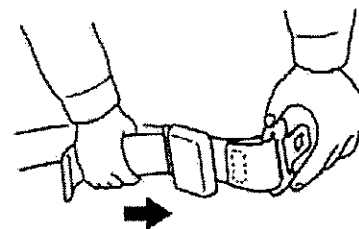

- When the belt length is short, lengthen the belt by adjusting it as illustrated.

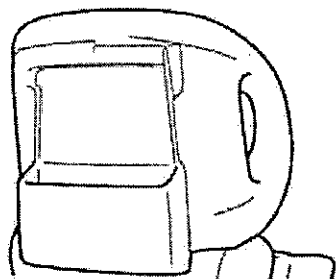

Magazine box

There is a box at the rear of the pocket for small items such as sketch boards and work gloves.

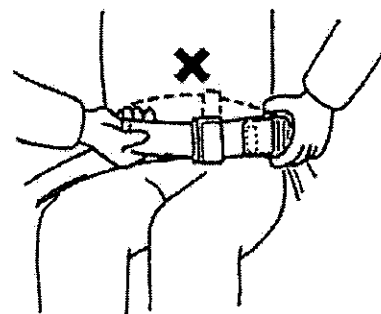

- Be sure that the belt is always set on the hip bone.
- Pull the belt to eliminate any slack, as illustrated.

Release

- Press the button in the center of the buckle. Set the released belt to the belt hook on the right side of the operator guard.

⚠ Caution

- Always buckle the seat belt when operating the vehicle.
- Always make sure the seat belt is disconnected when leaving the operator's seat.

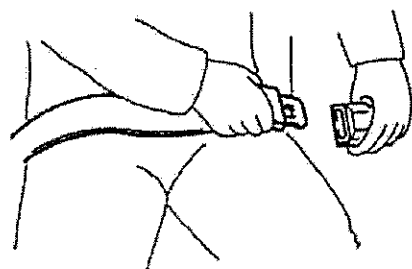

Seat belt

Application

- When buckling the belt, make sure that it is not twisted and insert the plate on the right side into the buckle on the left until it clicks to the position.

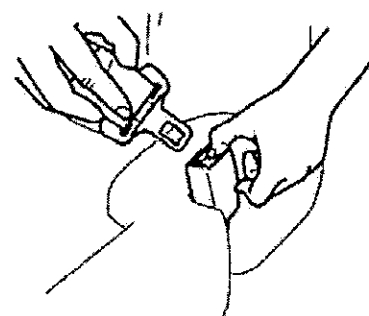

3 inches (57 mm) seat belt (Option)

To fasten your seat belt, pull it out of the retractor and insert the tab into the buckle. You will hear a click when the tab locks into the buckle. Pull on the belt to make sure the buckle is securely latched. The seat belt length automatically adjusts to your size.

Disconnecting method

Push the release button and allow the belt to retract.

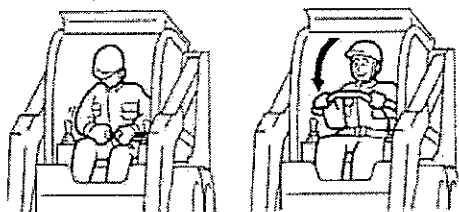

Seat bar

The seat bar is a device which protects the safety of the operator. Additionally, if it is not set in position properly, the interlock system will not allow the vehicle to travel and perform material handling operations. Set the seat bar in position properly by performing the following steps.

1. Sit down in the seat properly, and firmly fasten the seat belt.
2. Grasp the seat bar with both hands and lower it fully.

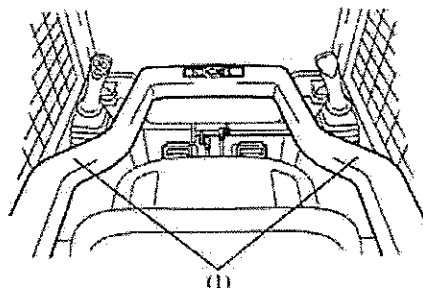

(1) Elbow-rest part

3. Place both elbows on the elbow-rest part so that the seat bar will be held from above.

⚠ Caution

- When driving, always set the seat bar in position correctly.
- Do not raise the seat bar while performing operations. Otherwise the material handling pedals (lift, dump) will be locked, and the traveling and material handling operations cannot be performed.
- When leaving the seat, always raise the seat bar completely, and make sure that the material handling pedals (lift, dump) are locked.

Operator guard

⚠ Caution

- Open the operator guard after making sure that the engine hood and the rear grille are closed.
- When opening the operator guard, in order to avoid falling off back, always perform the opening operation after supporting the rear part of the frame with a wood block or similar.

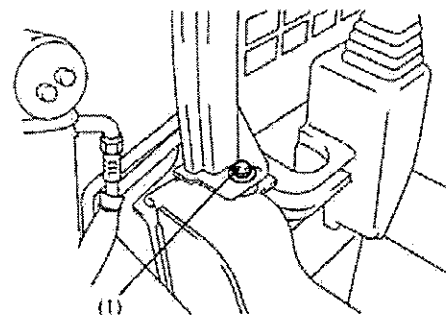

(1) Bolts

1. Move the vehicle to a flat, level place.
2. Turn OFF the parking brake disengagement switch and raise the seat-bar, turn OFF the ignition switch and pull out the ignition switch.
3. Slide the operator seat back to its fullest extent and climb out of the vehicle.
4. Support the rear part of the frame with a wood block or similar.
5. Remove the locking bolts on the left and right of the operator guard front side.
6. Standing up on the cross member of the frame front side, hold firmly the assist grip and slowly raise the operator guard.

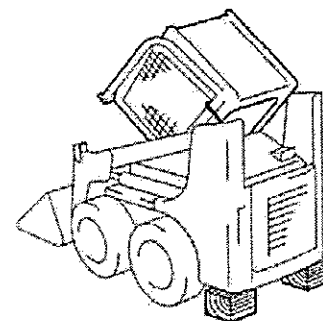

⚠ Caution

When opening the operator guard, always hold the assist grip with both hands and raise the operator guard slowly. If you raise it forcefully, the operator guard may bounce back causing the operator to be trapped underneath it.

7. Open the operator guard fully, remove the stay located inside the right rear side of the frame pillars from the stay catch, and hang it to the hook on the operator guard.

⚠ Caution

- Set the stay firmly into the stay catch so that it does not come loose.
- Under no circumstances raise the lift arm when the operator guard is open as there is a risk of falling.
- When the operator guard is closed tighten the bolts on the left and right securely.

Note:

On vehicles equipped with a pre-cleaner (Option), first remove the pre-cleaner and then open the operator guard.

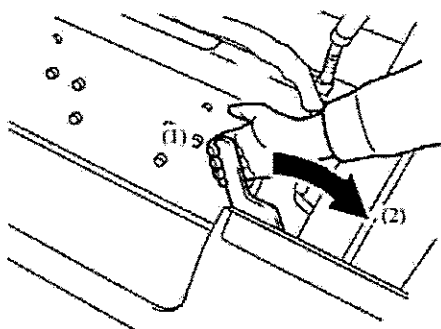

- (1) Lock
- (2) Lock release

Bucket lock lever

This lever is used when the bucket is replaced.

To lock..... Fold inwards.

To release Fold outwards.

⚠ Caution

- Make certain the bucket lock lever is operated after the bucket has been grounded and the engine stopped.
- Make certain the lever is operated after the operator has climbed out of the vehicle.

Note:

For more details, refer to the appropriate paragraphs of "the self-service, Replacing the bucket."

Rear hooks

Hooks are provided on both sides on the rear side of the frame for use in towing or transportation of vehicle.

⚠ Caution

- Use a sufficiently strong wire rope for towing.
- Use lifting hooks (Option) when lifting the vehicle.

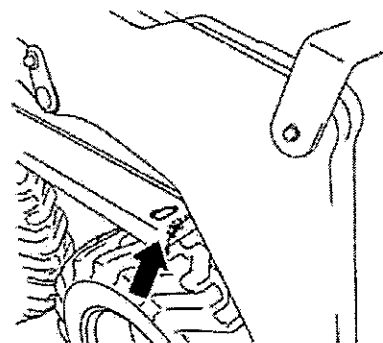
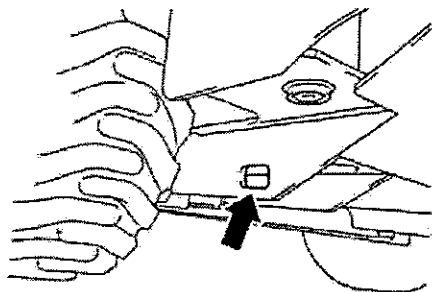

Lifting hooks (Option)

Use these hooks when lifting the vehicle. Front and rear lifting hooks are provided. Install the front hooks to the left and right positions on the front cross member, and rear hooks to insides of the left and right frame pillars.

⚠ Caution

Use sufficiently strong wire ropes when lifting the vehicle.

En

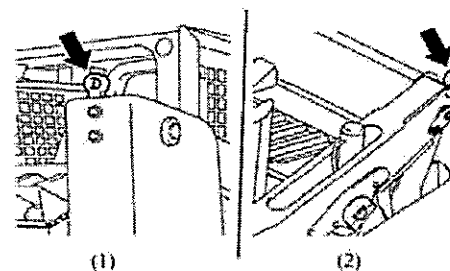

- (1) 30-5SDK5
- (2) 30-5SDK8, 9, 10, 11

Arm lock

This is a device which locks the lift arm preventing it from lowering when the operator needs to leave the vehicle during inspection and maintenance operations or while the arm is raised.

(The arm lock is mounted on the lift arm on the right side of the vehicle.)

Empty the bucket (remove the attachment), park the vehicle on a level ground, and mount the arm lock firmly onto the lift arm by performing the following steps.

⚠ Caution

- Always mount the arm lock if the lift arm requires essential inspection and maintenance, etc., and needs to be kept in the raised position. Lowering the arm during the operation is very dangerous.
- When climbing into and out of the vehicle, always make sure that the parking brake disengagement switch and the operation switch are turned OFF, turn OFF the ignition switch and pull out the ignition switch.
- When climbing into and out of the vehicle, under no circumstances depress the lift and dump pedals or touch the steering control levers.

Mounting the arm lock (30-5SDK5, 8, 9)

1. Remove the knob on the front side and pull out the lock pin.

Note:

Always store the removed knob and lock pin in a safe place to avoid losing them.

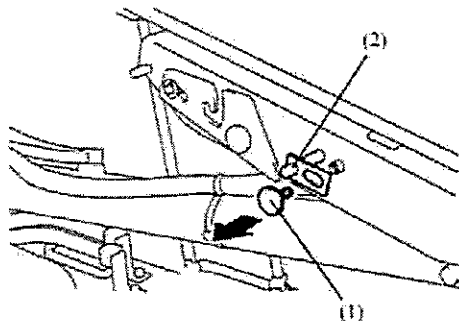

- (1) Knob
- (2) Lock pin

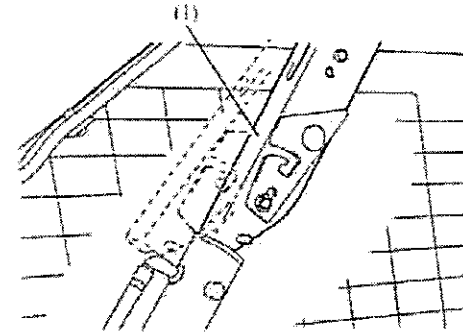

- (1) Lock

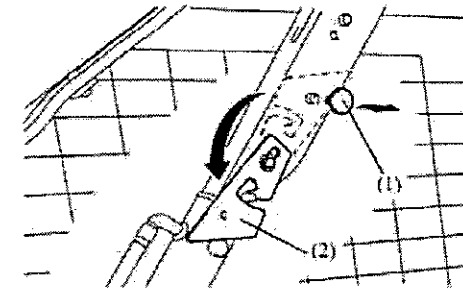

- (1) Knob
- (2) Release plate

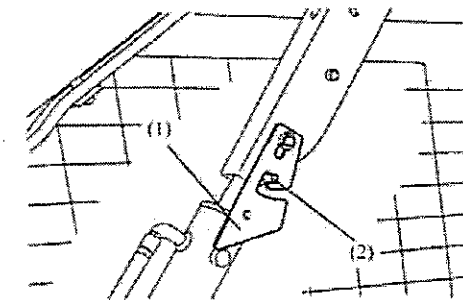

- (1) Release plate
- (2) Cylinder guide

2. Climb into the vehicle and sit in the seat, fasten the seat belt and lower the seat bar, start the engine, and raise the lift arm until the lock is set within the cylinder.
3. Lower the lift arm slowly until the lock is fixed in position.

⚠ Caution

When lowering the lift arm, always do it slowly. Sudden lowering may damage the cylinder rod.

Removing the arm lock (30-5SDK5, 8, 9)

1. Remove the knob on the rear side and move the release plate backwards.

Note:

Always store the removed knob in a safe place to avoid losing it.

2. Climb into the vehicle and sit in the seat, fasten the seat belt and lower the seat bar, start the engine, raise the lift arm and align the release plate with the cylinder guide.
3. Lower the lift arm completely and release the lock.

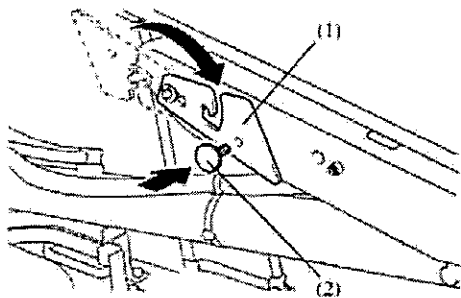

- (1) Release plate
- (2) Knob

4. Stop the engine, overturn the release plate and fix the knob.
5. Install the lock pin and fix the knob.

Mounting the arm lock (30-5SDK10, 11)

1. Remove the spring and pin.

Note:

Always store the removed pin in a safe place to avoid losing it.

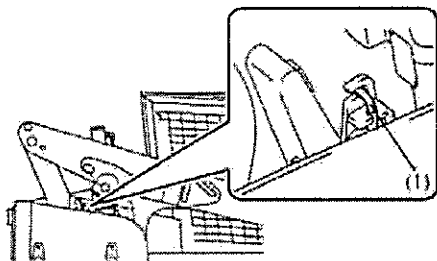

- (1) Pin

2. Join a to b by using the spring.
3. Climb into the vehicle and sit in the seat, fasten the seat belt and lower the seat bar, start the engine, and raise the lift arm slightly above to the point where the lock enters between the cylinders.
4. Lower the lift arm slowly until the lock is inserted between the cylinders.

⚠ Caution

When lowering the lift arm, always do it slowly. Sudden lowering may damage the cylinder rod.

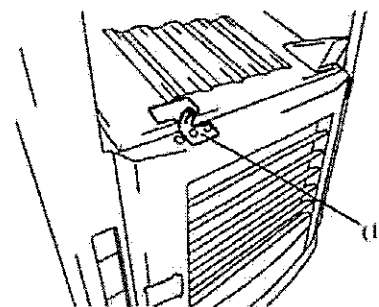
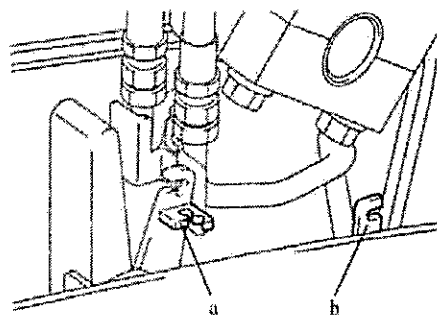

- (1) Locking bracket

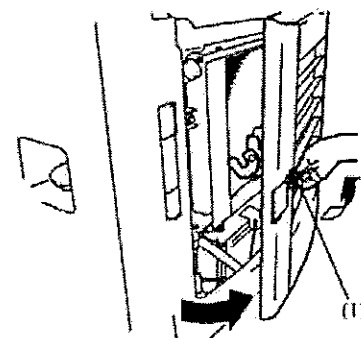

- (1) Grille lock lever

Removing the arm lock (30-5SDK10, 11)

1. Remove the spring which is joining a to b.
2. Climb into the vehicle and sit in the seat, fasten the seat belt and lower the seat bar, start the engine, raise the lift arm and release the lock.
3. Lower the lift arm completely.
4. After stopping the engine, climb out of the vehicle and return the pin to its original position.

En

Rear grille

Opening

1. Move the vehicle to a flat, level place.
2. Turn OFF the parking brake disengagement switch and raise the seat bar, turn OFF the ignition switch, pull out the ignition switch and climb out of the vehicle.
3. (Key-equipped rear grille model: Option) Remove the lock.
4. While pulling the grille lock lever up, carefully open the rear grille.

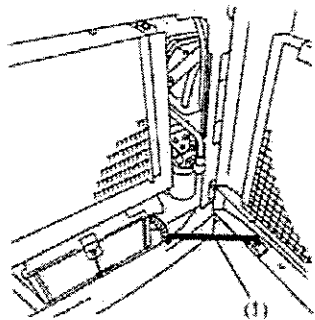

(1) Lock

5. Lock the rear grille by using the lock located at the bottom of the rear grille's inner side.

Closing

1. Remove the lock and return it to its original position.
2. While lifting the grille lock lever, close the rear grille carefully and take your hands off from the grille lock lever.
3. Make sure that the rear grille is securely locked.

⚠ Caution

Do not drive when the rear grille is open.

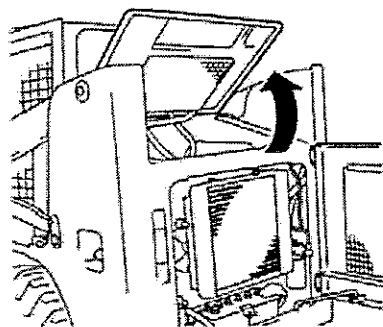

Engine hood

Opening

1. Move the vehicle to a flat, level place.
2. Turn OFF the parking brake disengagement switch and raise the seat bar, turn OFF the ignition switch, pull out the ignition switch and climb out of the vehicle.
3. Open the rear grille.
4. Raise the engine hood to its fullest extent and take your hands off from it.

Note:

The engine hood cannot be opened when the rear grille is closed.

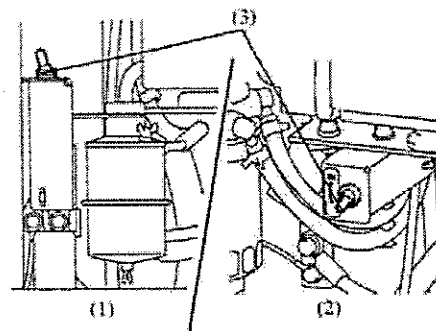

- (1) 30-5SDK5
- (2) 30-5SDK8, 9, 10, 11
- (3) Disconnect switch

Closing

1. Hold the engine hood with both hands and close it carefully.
2. Close the rear grille.

⚠ Caution

- Do not drive when the engine hood is open.
- When closing the engine hood, be careful not to get your hands, etc., trapped.

Disconnect switch (Option)

This switch cuts off any circuit related to starting the engine, and it is used to make the engine impossible to start.

Note:

Using in combination with a key-equipped rear grille model (Option) may be an effective way to prevent theft of the vehicle.

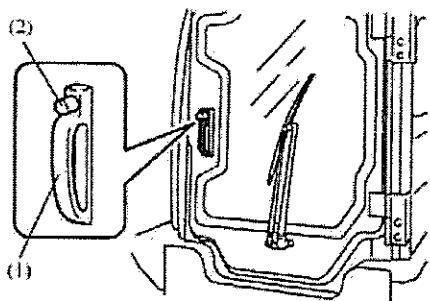

- (1) Door handle
- (2) Button

Using the cabin (Option)

Front door

Opening/closing (Outside the vehicle)

1. Press the button at the top of the door handle to release the lock, and grasping the door handle pull it towards you.
2. The lock will be engaged when the door is pushed closed completely by grasping the door handle.

⚠ Caution

- Open the door after stopping the vehicle safely.
- Before driving the vehicle, make sure that the door is closed securely.

Opening/closing (Inside the vehicle)

1. If the door inside lever is moved in the direction of the arrow, the lock will be engaged.
2. Grasp the door handle and open the door.
3. When closing the door, grasping the door pull handle and pulling it towards you to the fullest extent will engage the lock.

⚠ Caution

- Open the door after stopping the vehicle safely.
- Before driving the vehicle, make sure that the door is closed securely.

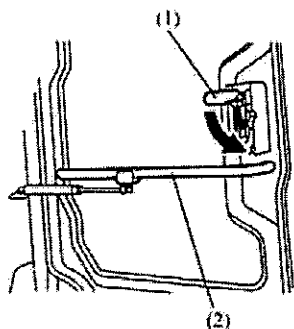

- (1) Door inside lever
- (2) Door pull handle

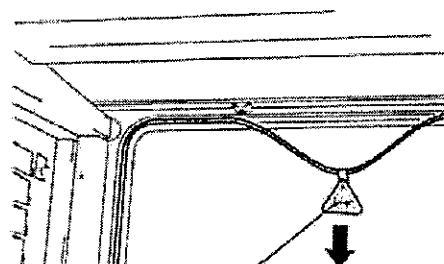

- (1) Tag

Rear window

The rear window at the back of the operator guard can be removed from the driver seat side, hence it can be used as an emergency escape exit.

Removing the rear window

1. Pull down the tag in the center of the rear window, and remove the whole of the trim rubber.

2. Push the rear glass outwards to escape from the vehicle.

⚠ Caution

The rear window is provided as a safety measure to protect the operator from behind. Do not remove the rear window other than in an emergency, and do not perform any operation when the rear window is removed.

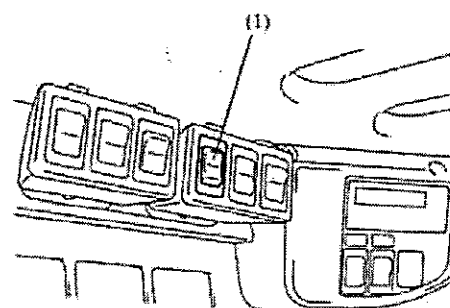
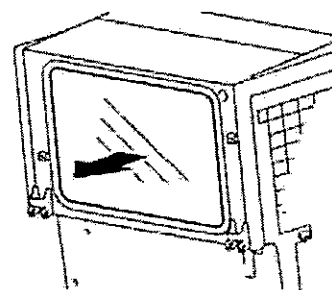

- (1) Front wiper switch

Front wiper switch (Option)

If the front wiper switch is pressed upwards, the wiper will operate.

Press the washer button at the bottom of the front wiper switch to release wiper fluid.

Note:

To inspect or replenish washer fluid, use the reserve tank located to the right of the driver's seat.

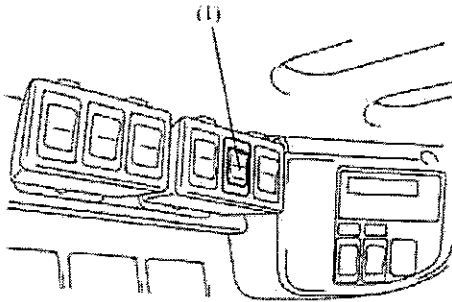

(1) Heater switch

Using the heater (30-5SDK5:Option)

The heater switch is located on the top left of the driver seat. It is used to turn the heater on and off (ON · OFF) and to change the amount of air flow between two settings (HI · LOW).

The air outlets are located at two places at the bottom of the driver seat: on the front right and on the top right side.

The direction and amount of air flow can be adjusted by operating the lever on the outlet section.

Note:

- Use the heater only after warming up the engine sufficiently.
- If the heater fan is left on for a long time when the engine is not running or when the engine is running at idle, the battery will run flat.
- If the heater is used for a long time, the air in the cabin may become stale and the window glass may get fogged. Therefore, open the window and let the air in the cabin change.

Using the air conditioner (30-5SDK8 · 9 · 10 · 11:Option)

The air conditioner control panel is located on the right side of the driver seat. It is used to turn the air conditioner on and off (ON · OFF), to change the amount of air flow between three settings (H, M and L), and to switch between cold air and warm air using the single step control.

The air outlets are located at two places at the bottom of the driver seat: on the front right and on the top right side.

The direction and amount of air flow can be adjusted by operating the lever on the outlet section.

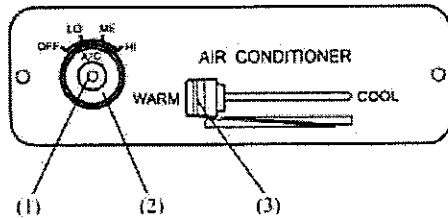

- (1) Heater ON/OFF switch
- (2) Air flow amount select switch
- (3) Cold air/warm air select switch

Note:

- To cool down the inside of the cabin quickly
Open both the door and window, expel the hot air from the cabin and turn on the air conditioner. After the cabin temperature has dropped, close the door and adjust the temperature to the desired level.
- In case of window glass fogging
During the wet season, etc., when the inside temperature of the cabin rises and the inside of the window gets fogged, the air conditioner can be used to clear the condensation away. Additionally, when the outside air temperature is high and the inside temperature becomes too low, the outside of the window may get fogged. Should this happen, adjust the inside temperature of the cabin by changing the temperature level setting or by switching off the air conditioner.

Precautions for the air conditioner when not in use

When the air conditioner is not being used for long periods, turn it on once or twice a month and operate it with the engine running at low revs, in order to prevent the lubricating oil of each part of the compressor from running out.

Note:

- If the air conditioner is left on for a long period of time, the inside of the compressor may burn hot and be damaged as a result of oil running out.
- Turn the air conditioner on once or twice a month and operate it for a few minutes. Perform this operation with the engine running at low revs. If the air conditioner is operated with the engine running at high revs, this may cause malfunctions.
- For refrigerant replenishment and inspection/maintenance operations, special facilities are required. Always contact your Toyota dealer to request these services.

CORRECT OPERATION

Handling new vehicles

Optimum performance and service life of your Toyota Industrial Vehicle are obtained with proper handling of new vehicles. During the first 100 hours of operation, pay special attention to the following items:

1. Do not unnecessarily race the engine.
2. Sufficiently warm up the engine after and before travel.
3. Avoid rough operation and unreasonable operation.
4. Always review new vehicle service and periodic inspection mentioned.
5. Lubricate, grease, and replace oil as recommended.

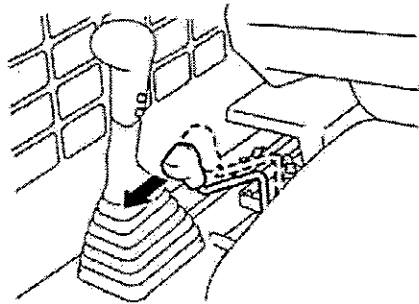

Engine starting and after starting

Sit in the operator's seat, fasten the seat belt, and lower the seat bar. Check that the parking brake disengagement switch is in the ON position.

Place the steering control levers and lift and dump pedals into NEUTRAL position. Pay special attention to safety in the surroundings and ventilation in a room or closed area.

1. Set the accelerator lever slightly forward from the idling position.
2. With the ignition switch in the ON (30-5SDK9 • 10 • 11) or GLOW (30-5SDK5 • 8) position, make sure that the glow indicator lamp (30-5SDK9 • 10 • 11) or the preheating indicator lamp (30-5SDK5 • 8) goes on once and in a moment i.e. 2-7 seconds case of 30-5SDK9 • 10 • 11, and approx. 15 seconds case of 30-5SDK5 • 8, it goes off again.
3. With the ignition switch ON, make sure that each warning lamp goes on.
4. Set the ignition switch into "START" position and activate the starter motor (continuous less than 5 seconds) to start the engine.
5. As soon as the engine starts, take hands off the key. It automatically returns to the ON position.

6. After the engine starts, return the accelerator lever to idle position. Make sure that each warning lamp goes off and that each instrument is operating normally and warm the engine up at idle.

Caution

The HST pump requires at least 5 minutes to warm up. For cold starting, see "Starting in cold weather."

En

Engine warming

Cultivate a habit of warming up the engine for several minutes irrespective of cold weather.

If the vehicle is operated before the engine gets sufficiently warm, each part of the engine is adversely influenced because lubrication within the engine and fuel combustion are difficult to take place properly.

Cylinder warm up

Before work begins every day, always make full stroke movement of the lift arm cylinders two or three times.

This movement enables the internal piston packing and cylinder to slide smoothly and puts the packing function in the same condition as during operation.

Caution

It is not good for the engine to be turned off suddenly while it is hot. Therefore do this only in an emergency.

Stopping the engine

1. Return the accelerator lever to the idle position and run the engine slowly for about 5 minutes, letting it gradually cool down.
2. Turn the ignition switch to OFF and remove the key.

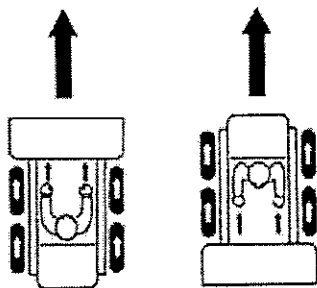

Vehicle operation

Starting

1. Operate the material handling pedals (lift, dump) or the steering control levers (material handling hand control vehicles; Option), raise the bucket 15-20cm (6-8in) from the ground and tilt the lift arm.
2. Turn ON the parking brake disengagement switch, and make sure that the parking brake warning lamp is switched off.
3. Move the accelerator lever forward and increase the engine revs.
4. Push left and right steering control simultaneously forward (or pull them backward) to make the vehicle travel forward (or backward).
Infinite speed change in the range between 0 and the maximum speed is possible by the degree of lever pushing (or pulling).

⚠ Caution

- Steering levers at the time of starting shall be operated as slowly as possible.
- During traveling, set the accelerator lever at a fixed position and use the steering control levers for speed adjustment.

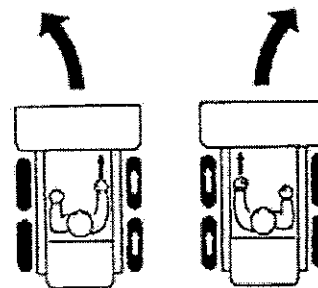

2. Pivot turn

Operating only the left one of the two steering control levers makes the vehicle turn with the right tires as the center. Operating the right lever causes a left turn around the left tires.

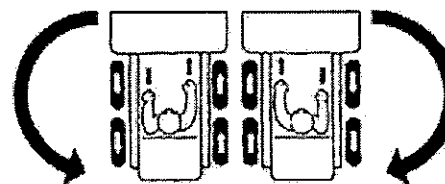

3. Spin turn

Operating the left and right steering control levers in the opposite directions makes the left and right tires rotate in reverse directions to cause the vehicle to turn around its center of gravity.

Direction change

Operate two steering control levers as explained below.

1. Slow turn

Varying the shift distances of the left and right steering control levers during forward or backward traveling makes the vehicle slowly turn to the side where the shift distance is smaller. The greater the difference between the shift distance of the two levers, the smaller the turning radius. The smaller the difference, the greater the turning radius.

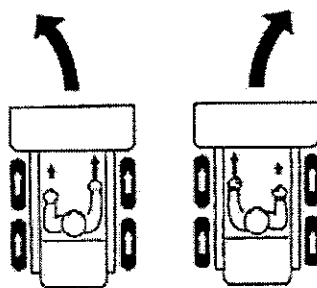

Stopping and parking

1. To stop the vehicle, return the left and right steering control levers slowly to the neutral positions.

⚠ Caution

Quick returning of steering control levers or operating them beyond the neutral positions to the reverse side of the traveling direction results in quick braking. Since this is very dangerous, never attempt such an operation unless in an emergency.

2. When parking the vehicle, park it in a convenient, level place where it does not interfere with other vehicles, and lower the bucket so that it rests on the ground.
3. Turn OFF the parking brake disengagement switch and raise the seat bar, turn OFF the ignition switch and pull out the ignition switch.

⚠ Caution

If circumstances do not allow to ground the bucket because of a malfunction or other reasons, park the vehicle at a place which is not near moving vehicles or pedestrians with a piece of red cloth attached to the tip of the bucket.

In such a case, make sure the lift arm is securely locked so that it is prevented from coming down either by locking it by means of the lift arm lock, the safety block, or the safety support.

Climbing out of the vehicle

When climbing out of the vehicle, use the assist grip and the step.

Driving on snow or icy roads

If the vehicle is to be driven on snow or icy roads, tire chains should be used. Never apply the brakes suddenly as this may cause the vehicle to slip or skid in snow or ice. Sudden acceleration or turning is also dangerous and should be avoided. Caution should also be exercised in operating the steering control levers.

⚠ Caution

Tire chains provide a large amount of traction to the vehicle but are of almost no help in preventing the vehicle from slipping sideways, so the vehicle must be driven cautiously.

MATERIALS HANDLING OPERATIONS

This vehicle is extremely effective in performing powerful hauling and material handling. For safe, economical handling, the operator must have a thorough knowledge of operations and a good grasp of the construction and performance features of the vehicle. Then, on the job, the operator must choose the operating approach and match the actual conditions with outstanding driving and operation techniques.

Never put more demands on the vehicle than performance or capacities allow. This not only increases repair costs, it jeopardizes the safety of the operator and nearby workers as well.

Any job must be undertaken with an eye on driver safety and others in the vicinity of the vehicle. Basic operation methods are explained here.

En

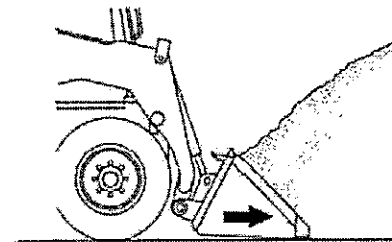
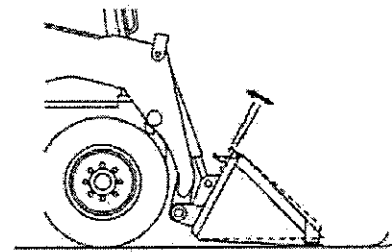

Bucket scoop operations

Move the vehicle forward slowly with the bucket held parallel to the ground or tilted slightly down, then raise the bucket by moving the tilt pedal towards the rear with your foot.

When the bucket is sufficiently full, tilt it back by moving the dump pedal towards the rear with your foot.

⚠ Caution

Always scoop with the bucket moving parallel to the material to be scooped. Do not allow the bucket to tilt as this will put excessive strain on the arm, bucket, and other parts and damage them.

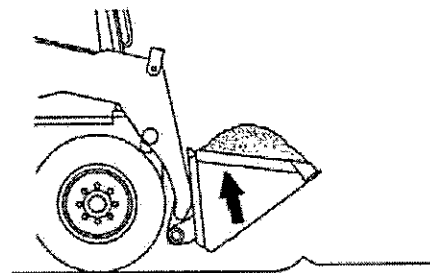
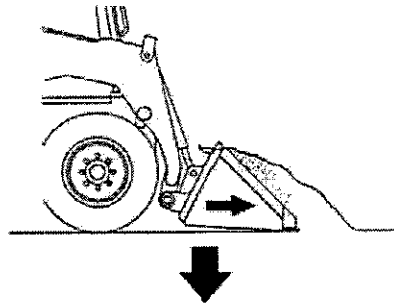
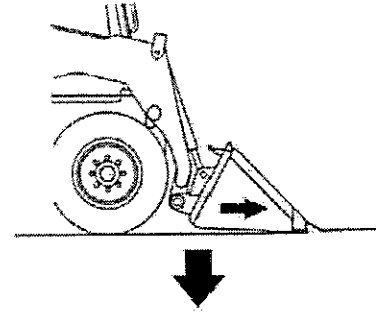
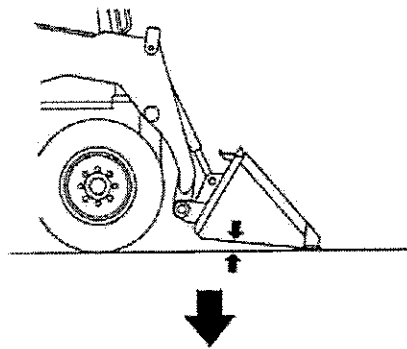
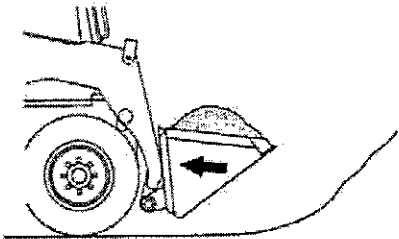
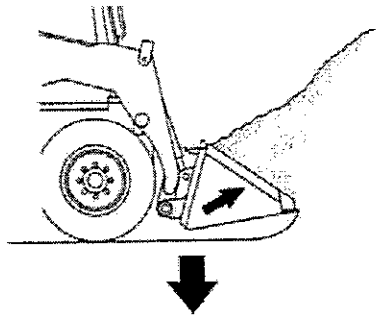

Bucket scrape operations

Advance with the bucket tilted down at the angle which ground hardness permits. Move forward slowly, letting the bucket scrape until it fills. Then, tilt back the bucket and haul away.

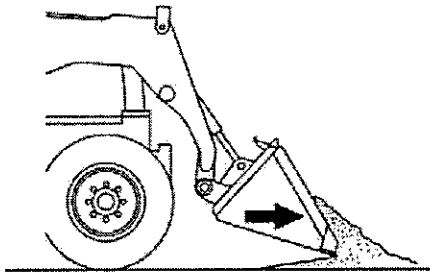

Grading and levelling

The bucket is tilted forward and raised slightly off the ground to perform grading and levelling jobs.

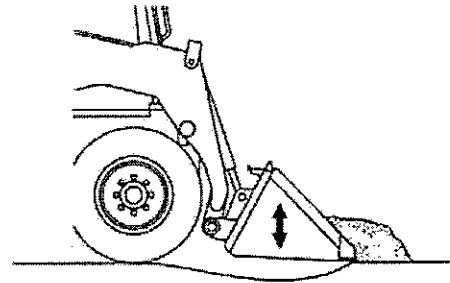

Float position

It is sometimes easier to work with the arm in the float position.

En

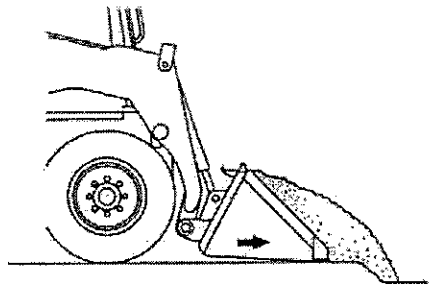

Filling

Hole filling and similar operations are possible.

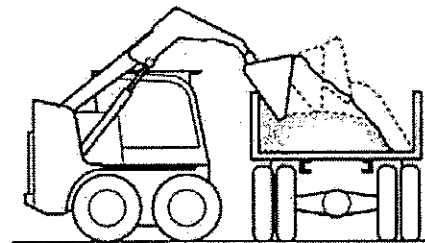

Material handling operations

Stop the vehicle near the truck and raise the bucket high enough to clear the upper edge of the truck.

Approach slowly, tilt bucket forward and stop vehicle.

Tilt the bucket forward to dump a bucketful in the truck.

The bucket may be used to level off the truck load.

To dislodge sticky material, shake the bucket up and down by gently moving the dump pedal back and forth.

⚠ Caution

Do not shake the bucket when unnecessary as this will put strain on the bucket stopper.

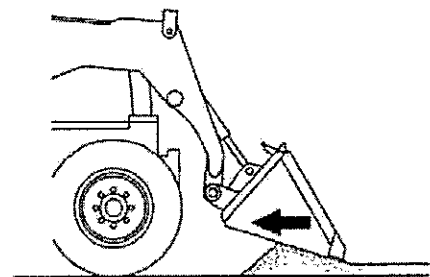

Backfilling

Backfilling can be done by tilting the bucket forward and backing up with the edge slightly off the ground.

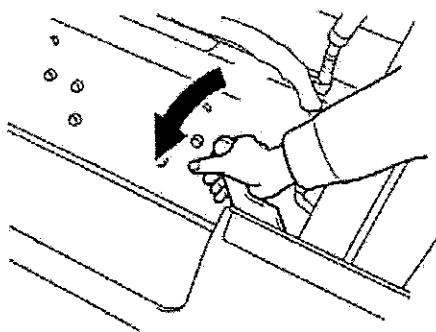

Replacement of bucket

Removing the bucket

1. First move the vehicle to a level and safe place, and then make the bucket level and ground it.
2. Set the parking brake disengagement switch to the OFF position. Stop the engine.
3. Climb out of the vehicle after making sure that the material handling pedal is fixed.
4. Set the bucket lock lever to the inside position.

⚠ Caution

Make sure the pins at the both sides of the bucket bracket have been removed completely from the bracket.

5. Climb into the vehicle, and start the engine. Release the parking brake.
6. Slightly lift the lift arm simultaneously slightly tilting the bucket in the forward direction and then move the vehicle backward as it is.

Mounting the bucket

1. Tilt the bucket bracket in the forward direction, bring the center of the bucket into the center line of the vehicle, and move the vehicle until it touches with the bucket.
2. Slightly raise the lift arm and tilt it to the backward.
3. Set the parking brake disengagement switch to the OFF position, stop the engine, and climb out of the vehicle after making sure that the material handling pedal is securely locked.
4. Set the bucket lock lever to the inside position.

⚠ Caution

- Make sure the bucket is securely fixed.
- Never mount or demount the bucket with the lift arm at a raised position.

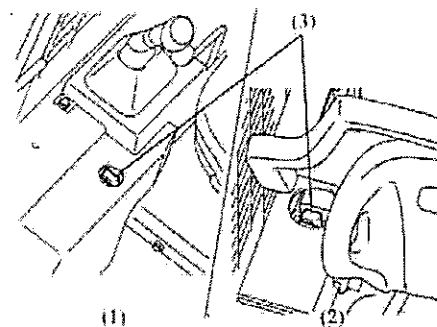
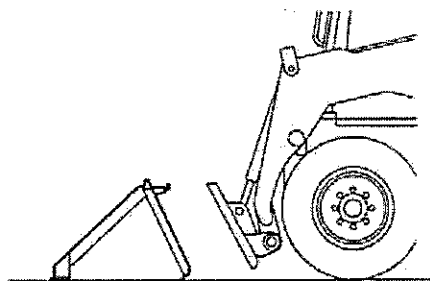

- (1) 30-5SDK5
 (2) 30-5SDK8 · 9 · 10 · 11
 (3) Emergency release lever

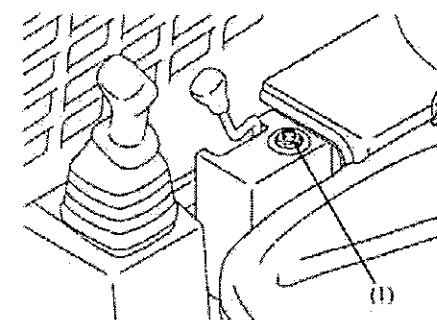
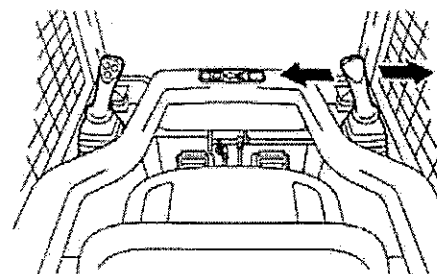

- (1) Pressure-relief button

Emergency lift arm lowering method

During operation, if lowering the lift arm becomes impossible, remove the cover located on the front of the accelerator lever (30-5SDK5) or on the rear of the accelerator lever (30-5SDK8, 9, 10, 11) and pull the emergency release lever.

⚠ Caution

When operating the emergency release lever, always leave the driver seat after making sure that the lift arm has been lowered to its lowest position. If the operator leaves the driver seat while the lift arm lowering is being performed, there is the danger of the operator getting trapped or otherwise injured.

Relieving pressure in the attachment hose (Option)

Relieving pressure

(30-5SDK5)

1. Turn OFF the parking brake disengagement switch.
2. Lower the lift arm completely and depress the lift pedal until it comes into the floating stage.
3. Turn OFF the ignition switch.
4. Move the steering control lever (at right side) to the left or to the right to relieve pressure in the attachment hose.

(30-5SDK8 · 9 · 10 · 11)

1. Turn OFF the parking brake disengagement switch.
2. Lower the lift arm completely.
3. Press the pressure relief button to relieve pressure in the attachment hose.

⚠ Caution

When relieving pressure in the attachment hose, always perform the operation after lowering the lift arm to its lowest position. Failing to do so may cause unexpected accidents.

HANDLING VEHICLE IN COLD SEASON

Pay attention to the following points in cold weather because starting difficulty or coolant freezing will occur.

1. **Caution when fueling**
Always replenish fuel until the tank is full. In cold weather, it is advisable to keep fuel tank levels high.

Caution

Firmly tighten the tank cap to prevent rain or snow from entering.

2. **Caution for cooling system**
 - (1) Long-life coolant (L.L.C.) 50% solution or antifreeze solution must be added to the cooling system (before outdoor temperature becomes lower than 0°C (32°F).)
3. **Caution for batteries**
 - (1) In very cold weather, the battery performance is lowered and battery fluid may freeze if charging is insufficient. Try to keep the battery always in the fully charged state.
 - (2) If the vehicle is not to be used for a long period of time in very cold weather, remove the battery and store in a warm place.
 - (3) Immediately before using the vehicle (or immediately before charging), replenish refined water in an exceedingly cold place.
 - (4) When it is difficult to start the engine, always do not apply hot water to the battery case to improve the battery performance. Pay special attention, because the case may be broken because of a change in temperature.

Starting in cold season

Low temperature causes battery performance to lower and viscosity of lubricating oil to increase, both of which make the engine starting more difficult.

In cold season, the engine is started in the following way:

1. Set the accelerator lever to maximum speed position.
2. With the ignition switch in the ON (30-SSDK9 • 10 • 11) or GLOW (30-SSDK5 • 8) position, make sure that the glow indicator lamp (30-SSDK5 • 8) or the preheating indicator lamp (30-SSDK9 • 10 • 11) goes on once and in a moment i.e. 2-7 seconds case of 30-SSDK9 • 10 • 11, and approx. 15 seconds case of 30-SSDK5 • 8, it goes off again.
3. With the ignition switch ON, make sure that each warning lamp goes on.
4. Set the ignition switch into "START" position and activate the starter motor (continuous less than 30 seconds) to start the engine.
5. As soon as the engine starts, take hands off the key. It automatically returns to the ON position.
6. As soon as the engine speed has stabilized, put the accelerator lever in the IDLE position and let the engine warm up for 10 or 15 minutes.

When it is difficult to start the engine

1. Do not use the starter motor continuously more than 30 seconds.
When it is difficult to start the engine, stop the starter motor operation momentarily and wait until the battery restores to restart.
2. When it is difficult to start the engine, do not repeat the starting procedure many times but inspect whether there is fuel in the fuel tank, whether air is mixed in the fuel system and whether the glow plug is not disconnected and the thermostat plug is not disconnected.
3. The engine may not reach the starting rpm and start even if the starter motor is activated. In such a case, use an auxiliary battery to start the engine.
Pay special attention not to connect mistakenly plus and minus terminals.

After using vehicle

1. Clean off any mud or dirt that may be adhering to the vehicle and park the vehicle on a hard, dry surface such as concrete. If this is not done, the mud may freeze during the night and prevent the vehicle from being operated the next morning. This especially applies to the surface of the hydraulic cylinder piston rods: always dry these off, because the rod packing can be damaged if water gets into it and freeze.
2. Loosen the fuel tank drain plug and loosen sediment drain plug and drain the water out of the fuel system to prevent it from freezing during the night.

Caution

When the cold season passes and the weather begins to warm up, bring the oil and fuel back up to standard specifications.

HANDLING VEHICLE IN HOT SEASON

During hot weather, the following areas are of concern:

Cooling unit

1. As water scale and rust easily take place in cooling system (especially in radiator) in hot season, remove water scale and rust with water or cleaning agent and always try to circulate clean water in the cooling system.
2. Clean radiator fins with compressed air to avoid clogging, resulting in overheating. Inspect the radiator for water leaks.
3. Inspect the fan belt for slack. If it is slack, adjust it to the prescribed tension.
4. When the engine is overheated and coolant boils, do not stop the engine immediately, but let it rotate at an idle speed for a while. After the water temperature drops, stop the engine. Also, open the engine hood to expedite cooling.

Heat protection function

If the hydraulic oil temperature reaches 85°C while performing material handling and attachment operations or while traveling, this function will activate a warning buzzer to warn the operator.

When the warning buzzer sounds, immediately stop operation and run the engine at a speed slightly faster than idling speed, and allow the hydraulic oil to cool.

Overheat automatic stop circuit

(Only on vehicles with Australian specifications)

If the hydraulic oil temperature reaches 100°C while performing material handling and attachment operations or while traveling, the material handling operation will stop.

When the material handling operation stops, immediately run the engine at a speed slightly faster than idling speed, and allow the hydraulic oil to cool.

⚠ Caution

- Do not remove the radiator cap to expedite cooling because it is very dangerous.
- If the HST oil temperature warning lamp lights and the warning buzzer sounds, stop the vehicle immediately, and allow the hydraulic oil to cool. If the engine overheats, the HST may be damaged.

LONG TERM STORAGE

Before storage without operation

If the vehicle is to be stored for a long period of time, pay close attention to the following:

1. Carefully wash and clean each part.
2. Perform lubrication and oil change for all necessary parts without omission.
3. Apply grease thinly on the exposed portions of hydraulic cylinder piston rods.
4. If a long life coolant is not used, thoroughly drain the coolant from the cylinder block and radiator.
5. Remove the battery after full charging, and store it in a cool, dry place.
6. Pull the accelerator lever fully backward and keep the ignition switch at the OFF position.
7. Store the vehicle indoors. If outdoor storage is unavoidable, place the vehicle on blocks and cover with waterproof canvas.

During storage

During storage, run the engine, move the vehicle back and forth, and operate each pedal at least once a month for lubrication of each part.

⚠ Caution

When operating hydraulic cylinders, wipe off grease applied to piston rods. Charge the battery sufficiently whenever the engine is started. (Supplementary charging is necessary every month to prevent degradation due to self discharge.)

After long storage

Pay attention to the following points when operating the vehicle that has been stored for a long period without operation.

1. Remove the drain plug from the fuel tank, oil pan, etc., to drain water accumulated in each part.
2. After starting the engine, carry out sufficient warm up and inspect each part carefully.

TRANSPORTATION

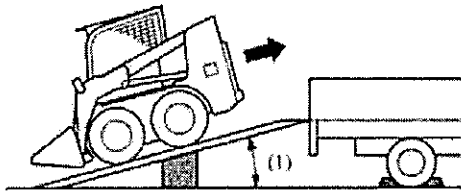

(1) within 15°

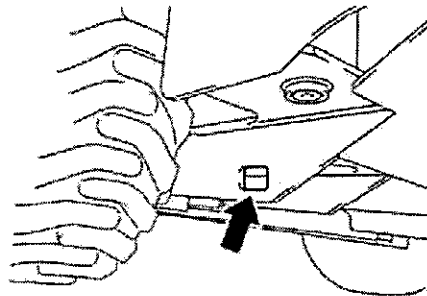
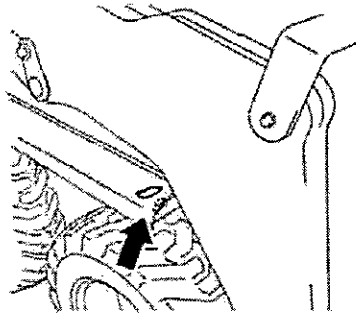

Use of a special platform is desirable for loading-unloading of the vehicle for transportation. When gangplanks have to be used, try safe operation, paying attention to the following points.

1. Stop the engine, apply the parking brake and block tires of the truck.
2. Set left and right gangplanks so that the truck and the vehicle are centered.

⚠ Caution

Use 450 mm or wider gangplanks which can sufficiently endure the vehicle weight. Fasten them firmly to the truck bed by using proper fittings. Install them without level difference between the left and right, and limit the board inclination within 15°.

3. Adjust the vehicle direction before getting on the gangplanks, and load the vehicle slowly by backward traveling.

⚠ Caution

- Never change the direction on the gangplanks.
 - Always assign a guide and carefully operate for ascending and descending on the gangplanks.
4. Set the parking brake disengagement switch to the ON position, fix the vehicle body to the truck bed with wire ropes and use wheel blocks to prevent vehicle movement during transportation. Bring the bucket into close contact with the truck bed. Fix the body to the truck bed as described below.
 - (Front side)
Pass wire ropes through the truck left and right fender fronts for fixing to the truck bed.
 - (Rear side)
Pass a wire rope through the left and right rear hooks for fixing to the truck bed.

PRE-OPERATION CHECK

Pre-operation check

Pre-operation checks and weekly inspections are the responsibility of the Toyota industrial vehicle user.

Be sure to perform a pre-operation check before beginning work to ensure safety.

Item	Inspection
Previously detected malfunctions	Correct.
Exterior	Vehicle posture, oil leakage, water leakage, loose parts; exterior damage.
Wheels	Tire pressure, wear or damage, rims; hub nuts.
Lamps	Lamp condition; damaged lamps
Hydraulic oil	Oil level, contamination, consistency.
Radiator	Coolant level, LLC or antifreeze requirement.
Engine	Oil level, contamination; consistency, noise; exhaust.
Parking brake	Braking action.
Levers	Looseness; functioning.
Horn	Sound.
Instruments	Functioning.
Load handling system	Parts, oil leakage; cracking; looseness.
Fuel	Amount.
Interlock system	Functioning & correct operating
Seat belt • Seat bar	Functioning & correct operating (including the metal fittings).
Operator guard	Any damage and deformation, mounting bolts for any looseness.

Walkaround inspection

Vehicle uprightness

Does the vehicle lean to one side or the other? If so, check for a tire puncture or a problem with the undercarriage.

Beneath the vehicle

Check for any oil or water leakage on the ground or floor where the vehicle was parked. Check for loose parts or damage. If any unusual condition is found, have the vehicle repaired.

En

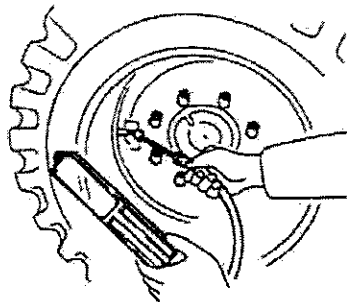

Tire inspection

Tire inflation pressure

1. Use a tire pressure gauge and measure the inflation pressure. Adjust it to the proper level.
 - See the service data section for the proper inflation pressure.
 - Do not raise the pressure beyond the proper level.
2. After the adjustment, check if air is not leaking from the valve.

Damage, crack and wear of tires and rims

Check the tires for damage and wear, and the rims for bending. If the tires are damaged, or there is a marked difference in the wearing of tires between the front and rear or between the left and right is perceived, or bent rims are found, ask a Toyota dealer for inspection.

Hub nut inspection

Check the tightness of the hub nuts. Avoid uneven torque and tighten all of the nuts uniformly. Even a slightly loose nut is dangerous. Refer to service data for proper torque.

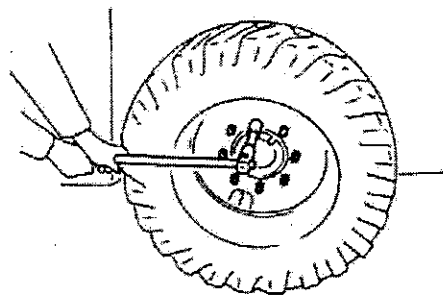

Lamp inspection

Are the filaments intact? Is there any lens damage?

Always keep the lenses clean to insure proper forward vision.

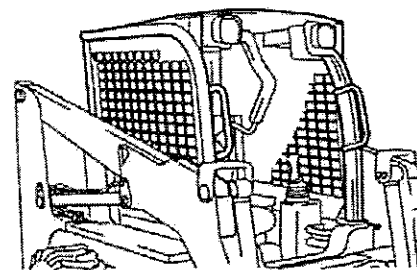
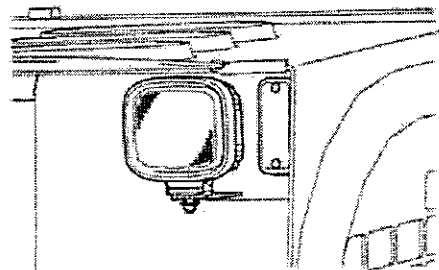

Operator guard inspection

Check the operator guard for any damage or deformation.

Also check the locking bolts for any looseness.

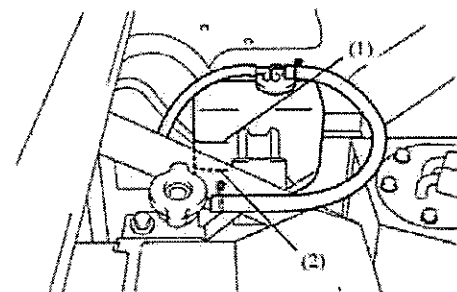

- (1) Full
(2) Low

Engine compartment inspection

Engine coolant level check and supply

Level check and supply of engine coolant shall be performed while the coolant is cool.

1. With the engine off, open the rear grille and engine hood, check the engine coolant level in the reservoir tank.

Note:

The reservoir tank equipped to the radiator automatically supplies the engine coolant when the coolant quantity in the radiator becomes insufficient.

2. The coolant level is proper if it is between the FULL and LOW line. If the level is below the LOW line, supply coolant to the upper limit.
3. The concentration of the long life coolant (LLC) in the engine coolant must be 30% (or 50% in a frigid zone.)

Note:

If no engine coolant remains in the reservoir tank, be sure to check the coolant level in the radiator, too.

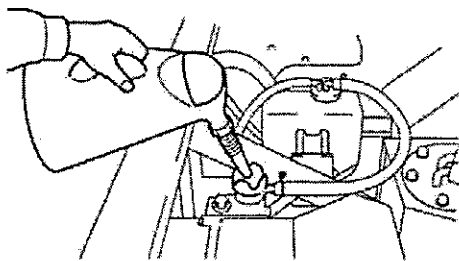

Checking the engine coolant level in radiator

1. Remove the cap and check the coolant level from the filler port.
2. If the engine coolant is not visible through the filler port, fill appropriately diluted coolant (LLC) to the port.

Note:

To close and tighten the radiator cap, match the pawl on the reverse side of the cap with the notch on the filler port and turn the cap fully clockwise while applying a downward force.

⚠ Warning

When the engine is hot, it is very dangerous to remove the cap. Coolant level check must always be performed when the engine is cold.

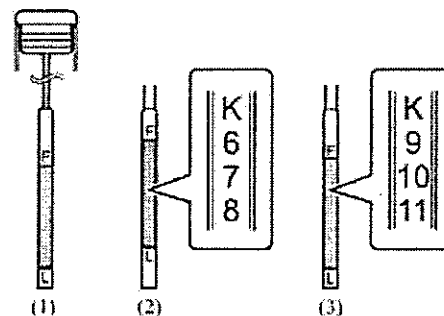

- (1) 30-SSDK5
- (2) 30-SSDK8·9·10
- (3) 30-SSDK11

Note:

Check the hydraulic oil level with the cap being inserted into the innermost end of the retainer.

3. Gently remove the level gauge and check that the oil level is between "F" and "L".
4. If the oil level is low replenish the supply. Wipe away any oil that is spilled when replenishing the supply.

En

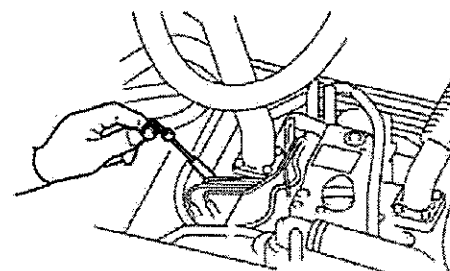

Engine oil inspection

Check the engine oil capacity before starting the engine.

Withdraw the oil level gauge, wipe with a clean cloth and reinsert all the way. Withdraw carefully and check the level up to which the oil adheres. If the level is between "F" and "L" or on level line, it shows a proper quantity.

⚠ Caution

Check the oil when the vehicle is parked on the surface.

As the accurate level cannot be obtained when it is checked immediately after the engine stops, wait three minutes.

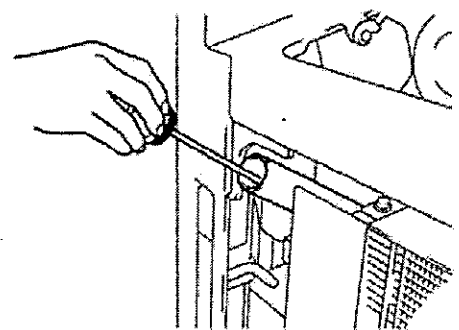

Hydraulic oil inspection

Always stop the engine and lower the bucket to the ground before checking the level of the hydraulic oil, while the vehicle is on level ground.

1. Open the rear grille and engine hood, and remove the oil cap.
2. Clean the level gauge on the cap with a clean cloth and replace it.

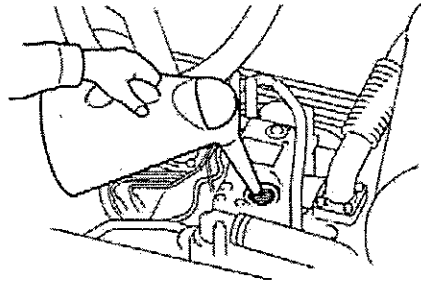

Engine oil replenishment

If the oil is near "L" level when checking replenish to the "F" level.

Remove the oil filler cap by turning it to the left and pour through it. Be careful not to pour more than "F" level. Use the engine oil fit for the season.

⚠ Caution

Use the same brand engine oil when replenishing whenever possible.

Note:

Drain out the engine oil with the plug of the drain hose being removed.

Leakage inspection

Check the engine compartment for any oil or fuel leakage.

Clean the radiator if it is clogged and check if there are any foreign objects, such as paper or other, onto the radiator grille.

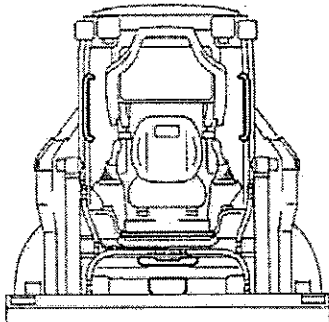

On board vehicle inspection

Step and assist grip inspection

Wipe mud, oil, grease, etc. off the step to cabin, grip, hand rail, floor surface and each pedal to prevent slipping.

Pay special attention to ice and snow in cold season.

Always use the step and assist grip installed on the vehicle as care must be taken not to slip and get hurt. Wipe oil and grease off your hands or mud off your shoes and slowly and safely get on the vehicle.

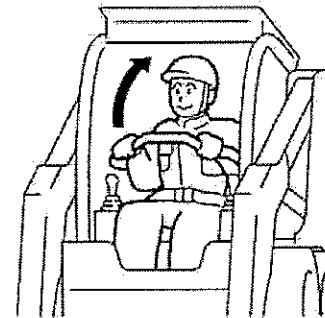
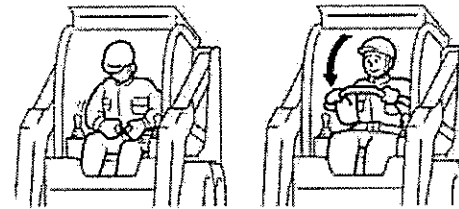

Seat belt inspection

Check the seat belt for any damage or normal operation. Replace the seat belt whenever the seat belt is found to have a fray or worn off, or a malfunction occurs in the metal fitting section.

Seat bar inspection

Check the seat bar for any damage or normal operation.

Also check the locking bolts for any looseness.

⚠ Caution

Do not operate with the seat bar removed.

Pedal lock function inspection

Note:

When inspecting the material handling pedals (lift, dump), after checking the pedal lock, turn ON the operation switch again and then perform the following steps.

1. Sit down on the operator's seat and make sure the material handling pedal is immovable by pressing it.
2. Make sure that the pedal lock is released and the material handling pedals (lift, dump) operate when the seat belt is fastened, the seat bar is lowered to its lowest position, the ignition switch is turned ON and the operation switch is turned ON.
3. Make sure the pedal lock is fixed when the seat bar is raised until unlocking under the condition described in preceding item 2.

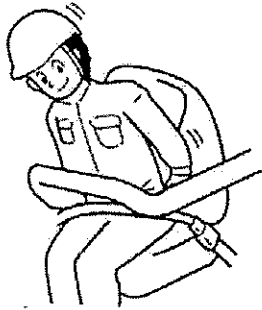

4. Make sure the material handling pedal will come to be fixed about a second after the operator has risen from the operator's seat under the conditions described in the above-mentioned item 2.

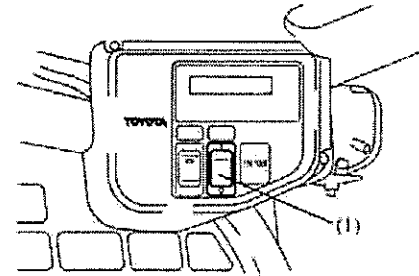

(1) Parking brake disengagement switch

Parking brake disengagement switch inspection

Turn OFF the parking brake disengagement switch, move the vehicle forwards slowly and make sure that the tires are completely locked.

⚠ Caution

If any abnormality is found, contact your Toyota dealer to request an inspection.

En

5. Make sure the material handling pedal will come to be fixed when the ignition switch has been turned OFF under the conditions described in the item 2.

⚠ Caution

If any abnormality is found, contact your Toyota dealer to request an inspection.

Starting the engine

Instrument inspection

Instruments are to know a state of the vehicle in operation.

Each warning lamp goes on by switching ON the ignition switch. Inspect whether the warning lamp normally goes off after the engine is started. Make sure that the hour meter also is operating normal.

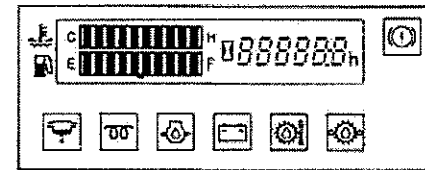

Operation switch inspection

Make sure that the operation switch is turned OFF and the traveling and material handling operations are disabled when the seat bar is raised, when the operator leaves the seat or when the ignition switch is turned OFF.

⚠ Caution

If any abnormality is found, contact your Toyota dealer to request an inspection.

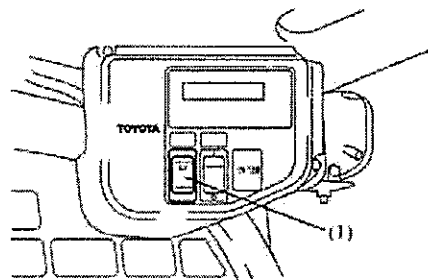

(1) Operation switch

Fuel level inspection and refueling

Check the amount of fuel using the fuel gauge. Fill with sufficient fuel for one day's work. When refueling fuel, perform refueling according to the following steps.



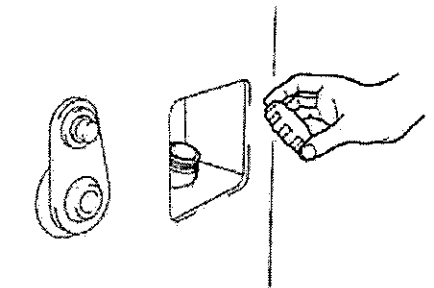
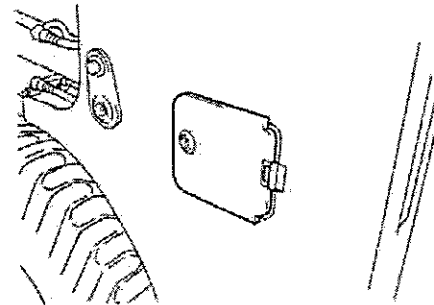
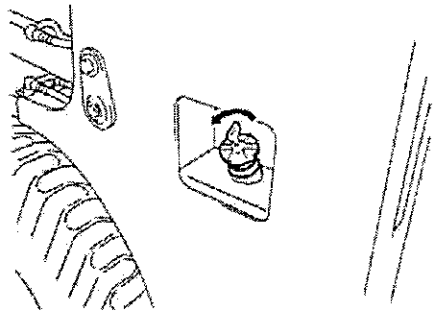

Fuel tank cap

1. Move the vehicle to a flat, level place, turn OFF the parking brake disengagement switch and the operation switch, and pull out the ignition switch.
2. (Vehicles equipped with a fuel tank cap key: Option)
Insert the key into the cap, turn it and release the lock.
2. (Vehicles equipped with a fuel tank cover key: Option)
Insert the key into the cover and open the fuel tank cover.
3. Turn the fuel tank cap to the left to remove it. There is a breather valve installed inside the cap.
If this valve is damaged or missing, the fuel may spray out.

⚠ Caution

- Never refuel near an open flame. Stop the engine before refueling.
- Retighten the cap securely after refueling.
- Do not allow water or dirt to get into the fuel.
- Fill the fuel tank every day after work to prevent moisture in the air from condensing and mixing with the fuel.

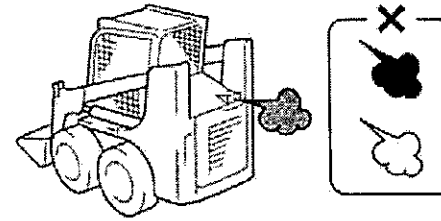

Engine inspection

Start the engine and warm it up sufficiently.

1. Check each meter and warning lamp to see there is no abnormality.
2. Check if the engine is generating abnormal sound or vibration.
3. Check the exhaust gas color to see it is normal.
Colorless or light blue exhaust indicates complete combustion; black exhaust, incomplete combustion; and white exhaust, burning oil as a result of oil getting into the cylinders.

⚠ Caution

The exhaust gas can cause serious injury if inhaled. If you must start the engine inside building or enclosure, insure sufficient ventilation.

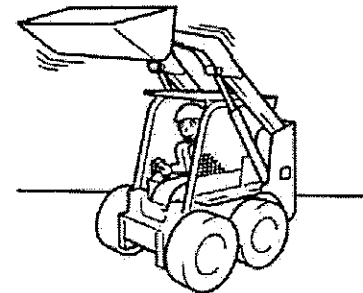

Material handling inspection

Inspect whether the bucket is firmly attached and whether there is any crack or bending. Is there any distortion in the arm? Any bending in the ring rod? Any oil leak from the cylinder and piping?
Operate the lift and dump pedal to make sure that each part is smoothly operating.

⚠ Caution

If any abnormality is found in the above inspection, have the vehicle repaired.

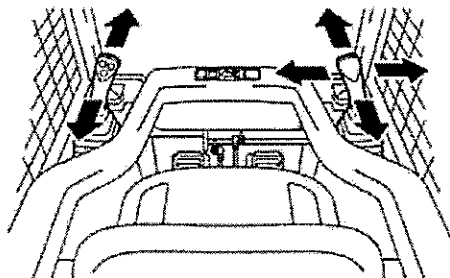

Steering control lever inspection

1. Move the levers in the forward and backward directions, and inspect them for abnormality.
2. When you release the levers, inspect whether they automatically return to the neutral position.

⚠ Caution

If any abnormality is found, contact your Toyota dealer to request an inspection.

While moving the vehicle

Parking brake inspection

By operating the steering control lever, inspect for abnormality or whether it is working on one side only.

Turning OFF the parking brake disengagement switch, make sure that the vehicle can stop as well as being able to maintain the stopped position.

⚠ Caution

When any slight abnormality is found, stop operation immediately. Report to the person in charge to the effect and ask our Toyota dealer for inspection.

Steering control lever inspection

While the vehicle is being driven slowly by operating the steering control lever in a safe place, inspect it for abnormality when the vehicle is spin to the left or right by operating the lever alternately. Also, inspect whether the lever automatically returns and the vehicle stops when the lever is released. Moreover, inspect speed change and switch over between forward and reverse by a degree of shifting the lever.

⚠ Caution

If any abnormality is found, have the vehicle repaired.

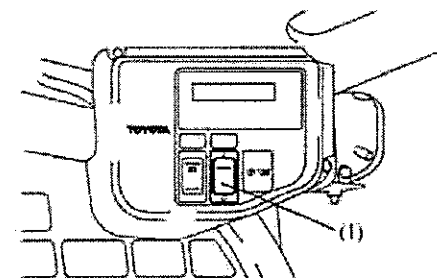

(1) Parking brake disengagement switch

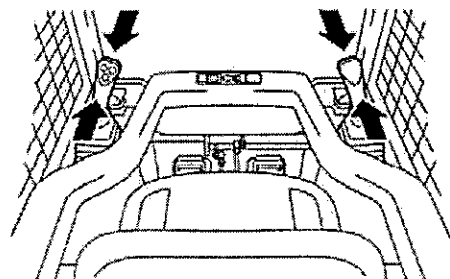

BEFORE GARAGING THE VEHICLE

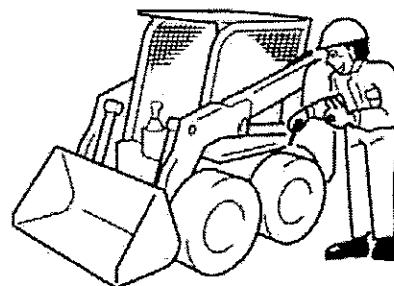

Remove dirt from all vehicle components and then perform the following.

1. Inspect for oil or water leakage.
2. Inspect each component for warping, scratches, dents or cracks.
3. Clean the air filter element and lubricate parts as required.
4. Raise the bucket all the way up and down to lubricate the inside of the lift cylinder.

⚠ Caution

Even a small malfunction can cause a serious accident.

Do not operate the vehicle until repairs have been completed.

If you sensed anything unusual during operation, notify the supervisor.

En

WEEKLY MAINTENANCE

INSPECTION AND SERVICE ITEMS	REMARKS
Replacement of HST oil filter Air cleaner cleaning Tightening of bolts and nuts Arm system lubrication Fan belt inspection Draining of fuel tank water-mixing, sediment. Battery electrolyte level	New vehicle

Inspect the items below in addition to the pre-operation items.

Have necessary adjustments or replacements performed.

Please inspect the vehicles thoroughly to insure safety and pleasant working conditions.

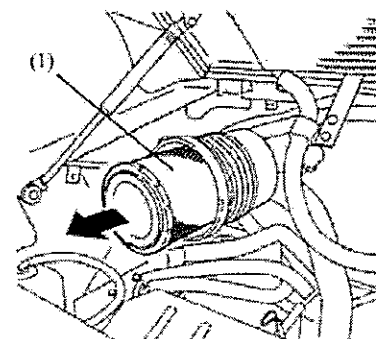

(1) Element

Air cleaner cleaning

The element can be taken out after removing the three catches fixing the element.

Element cleaning

1. Tap the element filter paper lightly without causing any damage or blow dust off with compressed air (700kPa [7kgf/cm²] or less) from inside.
2. After element cleaning, remove any dust in the evacuator valve.

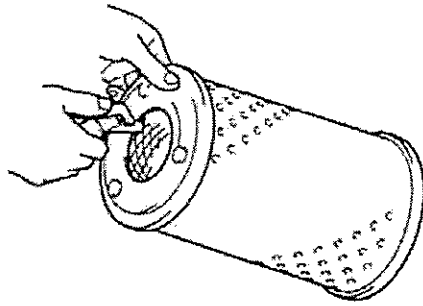

Note:

- Always replace the element if the filter paper is torn or damaged.
- Wash the element if heavily contaminated.

How to wash the element

1. Soak the element in water containing neutral detergent for approximately 30 minutes and then wash. Use care not to scratch the filter paper.
2. After washing, rinse the element with clean water (water pressure less than 280kPa [2.8kgf/cm²]).
3. Allow to dry naturally or use a dryer (cold air). Never use compressed air or flame.

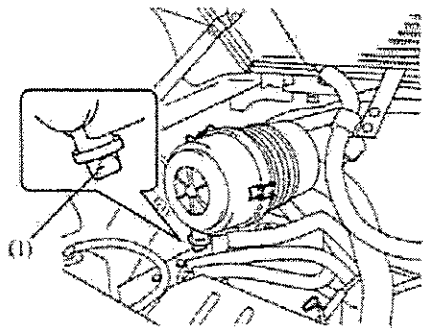

(1) Evaporator valve

Note:

- The element should be replaced after washing six times or after it is used for one year.
- It is unnecessary to clean the inside element when cleaning the double cyclone air cleaner (Option). Only clean the outside element. It is essential to replace both outside and inside elements, in time of replacement.

Fan belt inspection

If abnormality such as a crack and fray is found on the fan belt or its tension is weak, ask our Toyota dealer for replacement or adjustment. Loosen the alternator set bolt and activate the alternator for fan belt tension adjustment.

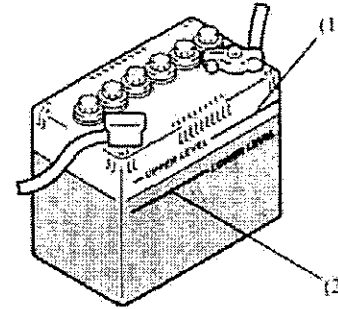
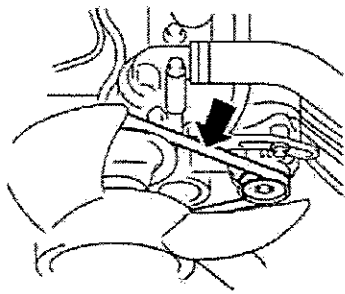

(1) Upper level
(2) Lower level

Battery electrolyte check

1. The battery electrolyte should be between the upper and lower levels (10 to 15 mm from the top of the plates).
2. If the electrolyte level is below the lower level, remove the cap and add distilled water to the upper level through the water inlet port.

⚠ Caution

Be sure to use distilled water for battery electrolyte. Also, wear protective glasses when working on the battery.

Note:

Perform battery maintenance after removing the radiator duct. The radiator duct can be removed by loosening the two bolts on its upper face.

Retightening of bolts and nuts

Retighten each bolt and nut on the chassis and load handling system.

Lubricating the arm system

Sufficiently lubricate the arm and cylinder portion joint pin.

⚠ Caution

Clean off the grease fitting nipples before lubricating. After lubricating, carefully remove any left-over grease.

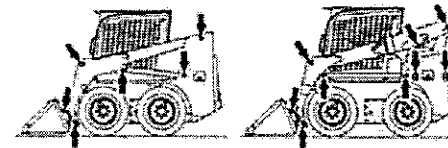

(1) (2)

- (1) 30-SSDK5·8·9
(2) 30-SSDK10·11

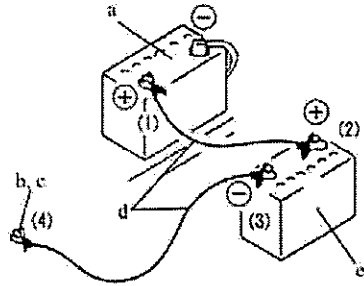

- a. Dead-battery vehicle
- b. Engine hanger
- c. To frame
- d. Booster cable
- e. Rescue battery

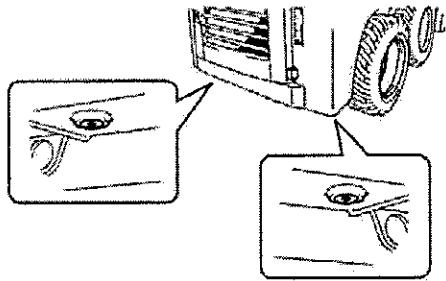

When the battery is dead

When a booster cable is available, it is possible to start the engine using the battery of another vehicle. Connect the booster cable following the sequence of the illustration. Make sure of (+) and (-) terminals of the cable when connecting.

⚠ Caution

- **Connection (1):** The (+) terminal of dead battery.
- **Connection (4):** Use a frame apart from the battery.
- **Do not directly connect batteries to avoid a danger of explosion.** (An inflammable gas generated from batteries may catch fire.)

Draining of fuel tank water-mixing

If you loosen the drain plug in the lower part of the fuel tank, the sediment and mixed water accumulated in the tank will be disposed together with the fuel.

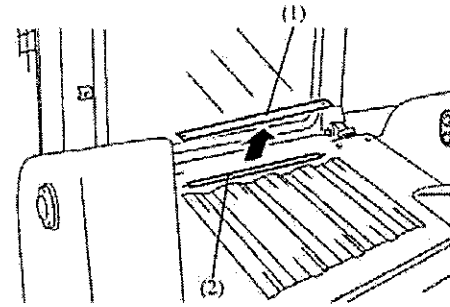

- (1) Cover
- (2) Opening

Oil cooler cleaning

Remove the cover of the opening located on the upper side of the engine, blow compressed air from below the engine hood and against its upper face so that any sediment is blown out of the opening. Then, open the engine hood and clean the cooler part too.

⚠ Caution

When cleaning by using compressed air, wear a dustproof mask and safety glasses. Also, perform the operation using compressed air at a pressure less than 200kPa (2kgf/cm²).

En

SELF SERVICE

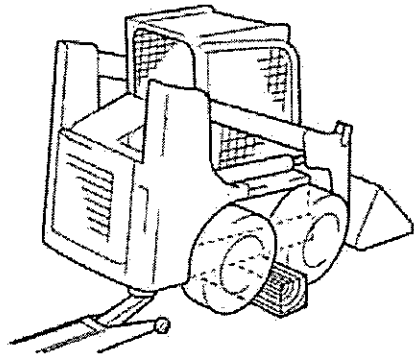
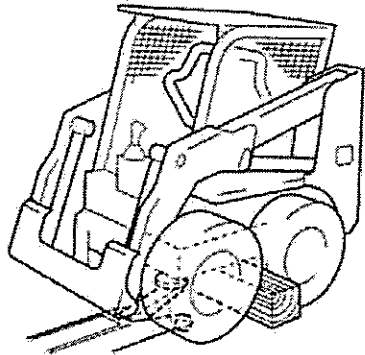

Changing tires

⚠ Caution

- Use proper safety precautions when jacking the vehicle. Never get under the bucket or frame.
- Refer to service data for hub nut tightening torque and tire air pressure.
- Tire air pressure is very high, so pay attention to rim deformation, cracks, etc. Never exceed proper air pressure.

Repairing flats, Replacing tires

Note:

Prepare tools and the jack, and securely block the wheels.

Front wheel

1. Dump the load, move the vehicle to a flat, level place, and lower the bucket until it touches the ground.
2. Slightly loosen the hub nuts.
3. Tilt the bucket forward, and with the tires off the ground, put blocks under the frame.
4. Remove the hub nuts and the wheel.
5. To re-install the wheel, reverse the removal procedure. Tighten the hub nuts evenly in the order shown in the illustration.
6. After installing the wheel, check the tire pressure and adjust it if necessary.

Note:

See the Service Data for tightening torque of hub nuts and tire pressure.

Rear wheel

1. Locate the vehicle on level ground.
2. Apply the parking brake, securely block the wheels and slide the jack under the frame.
3. Jack up the vehicle until the tires are in light contact with the ground and loosen the hub nuts.
4. Jack up the unit until the tire is off the ground, remove the hub nuts.
5. After tire repair or replacement of tire, reverse the removal procedures to mount the tire and wheel. Tighten the hub nuts as shown in "Front wheel" section.

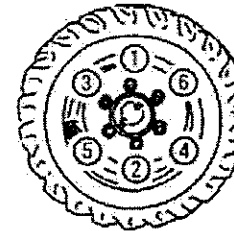
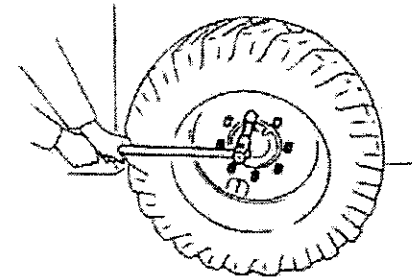

(30-SSDK5)

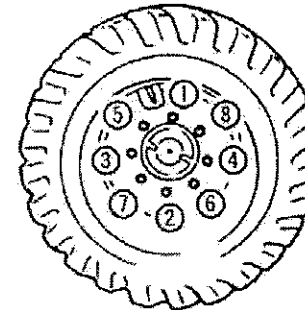

(30-SSDK8 • 9 • 10 • 11)

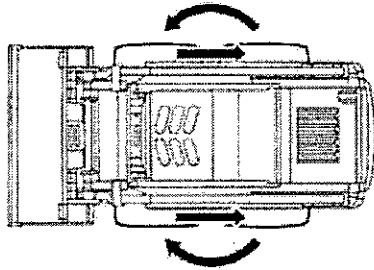

Tire rotation

Rotate the tires as shown when they show wear. Note that the direction of the tire patterns of the left and right tires will become reversed when the tires are rotated.

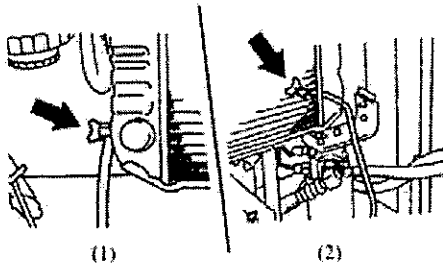

- (1) 30-5SDK5
- (2) 30-5SDK8 · 9 · 10 · 11

Adding antifreeze

If the vehicle is left in an area where the temperature is less than 0°C (32°F), the cooling water will freeze and may damage the radiator and/or cylinder block if antifreeze is not added. When long-life coolant (LLC) is used, it must be changed once every two years. Freezing temperature varies depending on the amount of antifreeze added.

Antifreeze solution mixing capacity (%)

Antifreeze temperature (°F)	10.4	5	-11.2	-31
Antifreeze temperature (°C)	-12	-15	-24	-35
Mixing ratio (%)	25	30	40	50

⚠ Caution

Prior to adding antifreeze, inspect the radiator, water pump, piping and block for leaks. The procedures for adding antifreeze are as follows.

1. Remove the radiator cap, loosen the drain cock on the radiator and engine block and drain the cooling water.

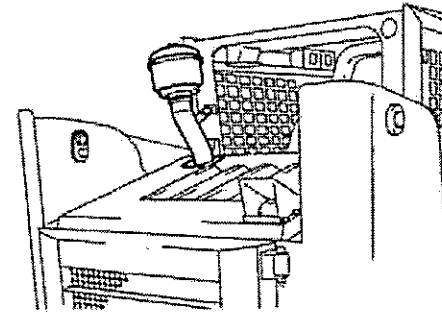

2. Flush out the radiator and cylinder block by adding clean water through the radiator inlet.
3. After the water has drained out of the radiator and engine block, fully tighten the radiator and engine drain cocks.
4. Add the proper amount of antifreeze to the radiator inlet and fill up the remaining space with water.
5. Also change the coolant in the reserve tank, adding water and antifreeze in the same proportion.

En

Cleaning of Pre-cleaner (Option)

Inspect the pre-cleaner and clean it if dust has accumulated up to the white line.

Note:

When opening the operator guard, remove the pre-cleaner.

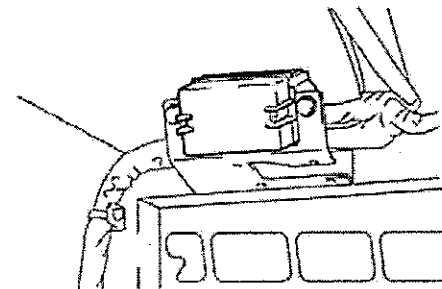

Fuse replacement

If a lamp does not come on or an electrical device does not function, the corresponding fuse may be blown. Check the fuse for each device. The fuse box is located in the left front as seen from the top left of the driver seat.

Note:

See the table below for the device corresponding to each fuse.

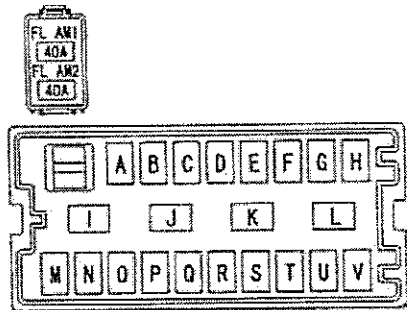

Fuse assignment

A	20A	RR WIPER
B	20A	FR WIPER
C	15A	ALT
D	7.5A	STOP
E	7.5A	GAUGE
F	15A	IGN
G	15A	ACC-B
H	7.5A	ST
I	30A	SPARE
J	20A	SPARE
K	15A	SPARE
L	7.5A	SPARE
M	7.5A	GLOW
N	30A	KEY-STOP
O	15A	HEATER
P	15A	WORK LP
Q	15A	HEAD
R	7.5A	TAIL
S	15A	TURN
T	15A	HORN
U	30A	STA
V	7.5A	ALTS

Including optional accessories

The fuse check and replacement procedures are as follows:

1. Set the ignition switch to the OFF position.
2. Remove the fuse box cover and take off the clip attached to the fuse box.
3. Apply the fuse clip to a fuse to remove the fuse.
4. The fuse is blown if its state is as shown at right in the left illustration. Replace it with a spare fuse.

⚠ Caution

- Use the fuse having the same capacity as that of the installed one.
- If the replaced fuse is blown again, ask a Toyota dealer for inspection.
- Ask a Toyota dealer to replace the GLOW or ALT fuse, if necessary.

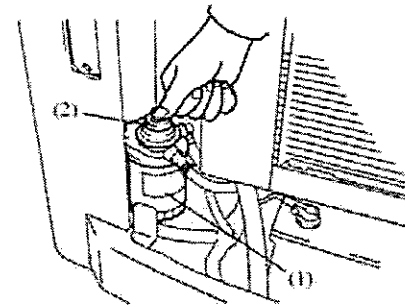
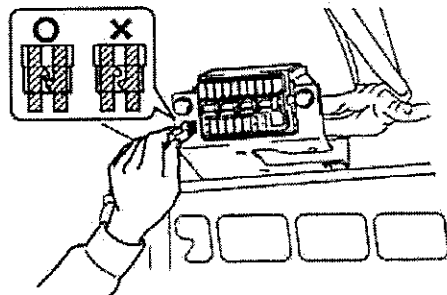

- (1) Fuel filter
(2) Priming pump

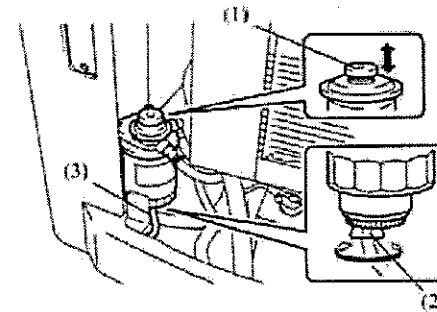

- (1) Priming pump
(2) Drain plug
(3) Drain hose

Air purge of the fuel system

When fuel has been completely depleted or when maintenance has been performed on the fuel system, be sure to perform air purge in the following sequence.

1. Open the rear grille.
2. Operate the priming pump up and down to perform air bleeding.

Draining the sedimenter

The sedimenter separates the water contained in the fuel. It is integrated with the fuel filter. If the sedimenter warning lamp comes on, immediately drain water according to the following procedure because the accumulated water in the sedimenter is above the specified level.

1. Place a water receiving container under the open end of the drain hose under the fuel filter.
2. Turn around the drain cock a time or two to loose it and operate the priming pump up and down to drain the water in the sedimenter.
3. When light oil starts to flow out after the end of water draining, firmly tighten the drain cock.

⚠ Caution

Wipe the light oil cleanly from the adjacent area.

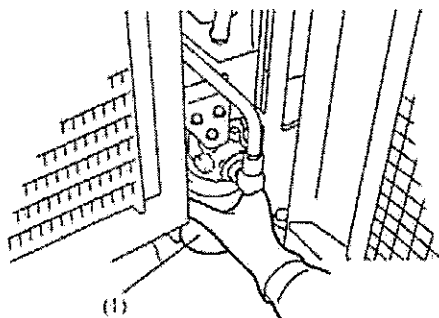

(1) HST oil filter

HST oil filter replacement

The HST oil filter should of course be replaced whenever the HST filter warning lamp goes on, but it should also be replaced after 50 hours the first time and after 500 hours (or 1 year) thereafter, regardless of whether the warning lamp lights or not.

The oil filter replacement is easy when the rear grille is opened.

Cleaning the radiator fin

Clean the radiator and radiator fin. If debris is trapped therein, this may cause over-heating.

⚠ Caution

- After stopping the engine, confirm that the engine has sufficiently cooled down before conducting cleaning. Not taking adequate precautions may result in burns.
- When cleaning the radiator fin, take care not to cause it to become deformed.
- When performing cleaning, always wear safety goggles and dust mask.

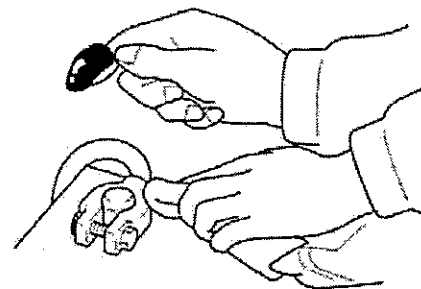

Maintaining the battery

Terminals

1. A loose or corroding terminal causes failure in connection: Eliminate white powder, if noticed on the terminal, by pouring warm water over it to disable and then grease the terminal.
2. Remove the terminal, if it is extremely corroded, from the battery to brush off the corrosion using a wire brush or sandpaper. Then connect the terminal tightly to the battery and grease the terminal.

Note:

Remove the negative terminal (-) first, but replace the same, second.

⚠ Caution

- Stop the engine when attempt to work on the battery and terminals.
- Be careful not permitting any foreign matter to come into the battery by means of putting the lids tightly in place.
- Be careful not causing a short circuit on the battery nor nearing fire, such as smoking fire, because the battery-emitted gas is inflammable.
- Be cautious enough not to contact the battery electrolyte. When it comes into contact with an eye or skin, wash it off immediately with plenty of water and then see a doctor.
- Charge the battery with the lids off in a well-ventilated area.
- When battery electrolyte is spilt, be certain to wash it off with water thoroughly the spot and adjoining area.

En

FUEL TANK CHECK

Check fuel tank, tank covering, fuel inlet, and drain plug against possible fuel leak. Follow the steps below.

1. Try to smell leak.
2. Look for leak.
3. Touch possible leak.

See the nearest Toyota dealer upon finding leak and have them repair tank immediately.

FRAME SERIAL NUMBER

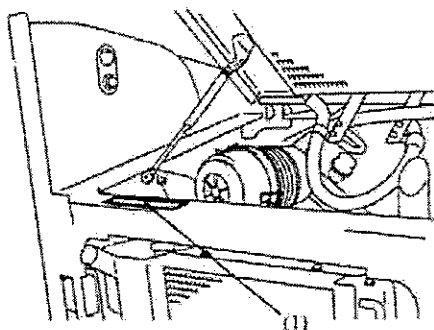

(1) Frame serial number location

Vehicle model	Serial number
30-5SDK5	305SDK5-10001
30-5SDK8	305SDK8-10001
30-5SDK9	305SDK9-10001
30-5SDK10	305SDK10-10001
30-5SDK11	305SDK11-10001

⚠ Caution

Never perform do-it-yourself welding or other repair work for it might cause explosion or fire.

Frame serial number location

The frame number is on the top of the inner frame of the engine room.

When you notify Toyota industrial Vehicle Toyota dealer of your vehicle abnormality, always inform them of the FRAME NUMBER.

HOW TO READ THE NAME PLATE

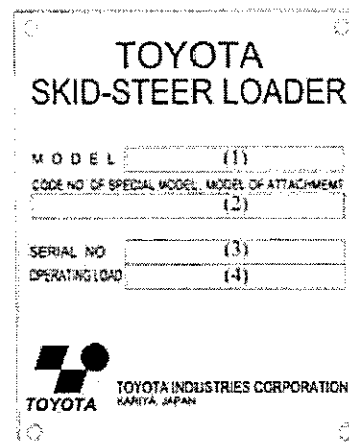

The load capacity is engraved on the name plate.

Make sure of the load center and capacity before starting the operation.

1. Vehicle type
2. Special vehicle type, Attachment type
3. Serial No. (Frame No.)
4. Operating load

LUBRICATION CHART

30-SSDK5 - 8 - 9

1. Arm and cylinder each portion joint pin
 2. Engine crank case
 3. Hydraulic oil tank
 4. Chain case
- i) Inspect every 8 hours (daily)
 - ii) Inspect every 40 hours (weekly)
 - iii) Inspect every 250 hours (6 weeks)
 - iv) Inspect every 500 hours (3 month)
 - v) Inspect every 1,000 hours (6 month)

- :Inspect and service
●:Replase
- (A) Multipurpose grease
(B) Diesel engine oil
(C) Diesel engine oil
(D) Diesel engine oil

*1: 30-SSDK8, 9
*2: 30-SSDK5

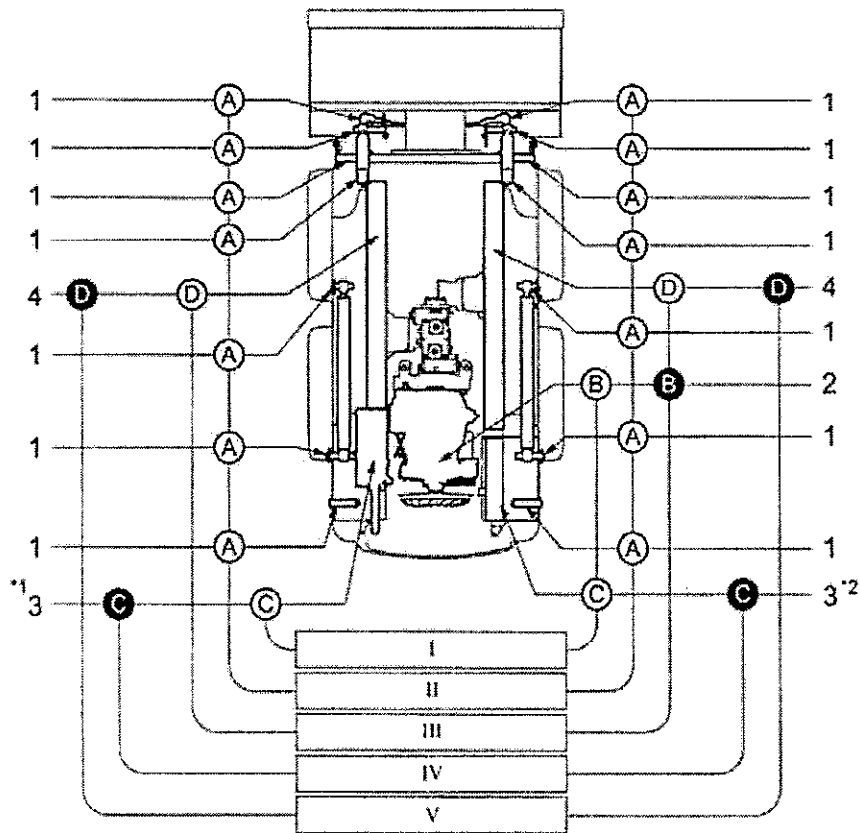

30-SSDK 10 - 11

1. Arm and cylinder each portion joint pin
 2. Engine crank case
 3. Hydraulic oil tank
 4. Chain case
- i) Inspect every 8 hours (daily)
 - ii) Inspect every 40 hours (weekly)
 - iii) Inspect every 250 hours (6 weeks)
 - iv) Inspect every 500 hours (3 month)
 - v) Inspect every 1,000 hours (6 month)

- :Inspect and service
●:Replase
- (A) Multipurpose grease
(B) Diesel engine oil
(C) Diesel engine oil
(D) Diesel engine oil

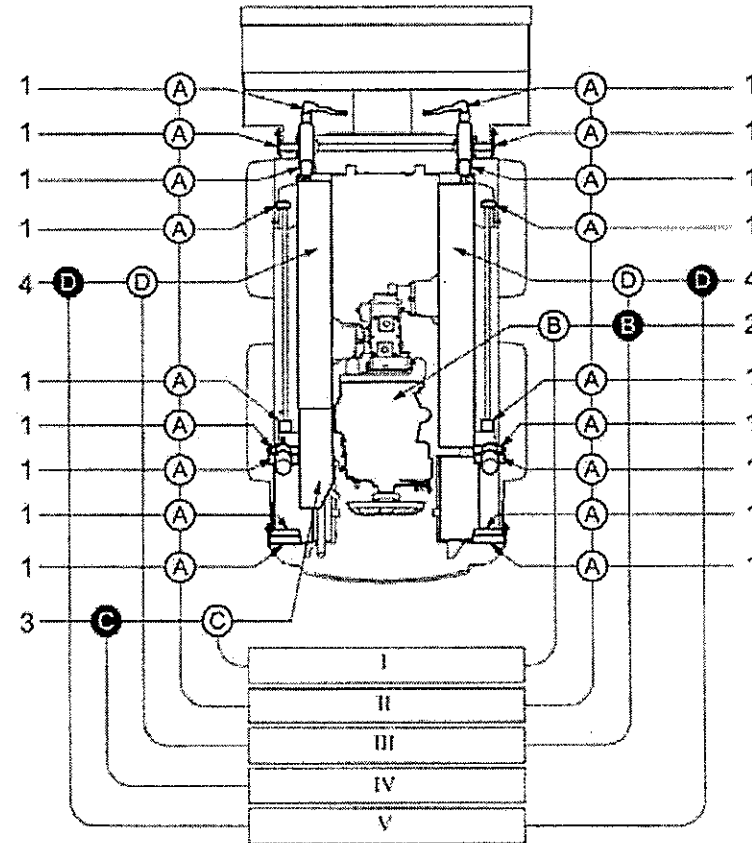

En

PERIODIC MAINTENANCE

Pre-operation check

Periodic inspection and maintenance are necessary to keep your Toyota industrial vehicle running smoothly. The designated number of hours in the inspection cycle are as follows.

Daily (pre-operation check).....	Every 8 hours
Weekly	Every 40 hours
6 weeks.....	Every 250 hours
3 month.....	Every 500 hours
6 month.....	Every 1,000 hours
Annually.....	Every 2,000 hours

PERIODIC REPLACEMENT TABLE

REPLACEMENT PERIOD (Accumulated hours of operation or monthly periods of operation, whichever comes soonest.)	EVERY	6 WEEKS	3	6	12	MONTHS
	EVERY	40	250	500	1,000	2,000
Engine oil		●	←	←	←	←
Engine oil filter		●*	←	←	←	←
Coolant (except LLC, LLC is every 2 years)			●	←	←	←
Air cleaner element (Replace every 6-times cleaning)						●
Fuel filter				●	←	←
Hydraulic oil			●	←	←	←
Reduction device oil				●	←	←
HST oil filter (Replace by warning lamp indication)		●*1				
Fuel hose						(Every 2 years)
Hose for loading						(Every 2 years)
Hose for HST						(Every 2 years)

Note:

In case of the hard operating condition, the service interval of 170 hours or 1 month may be recommendable.

If operation time exceeds 250 hours within 6 weeks use the number of hours as the guide for performing periodic inspection. Preoperation checks and weekly inspections should be performed by the user. 6 week, 3 month, 6 month and annual inspection should be performed by a Toyota Dealer since high-level technology and special tools are required.

Refer to the periodic table to determine inspection and maintenance items and inspection cycles.

Use only genuine Toyota parts for replacement parts, and use the recommended types of lubricants.

PERIODIC MAINTENANCE TABLE

Periodic maintenance

INSPECTION METHOD

I: Inspect and correct and replace as required. T: Tighten C: Clean L: Lubricate M: Measure and correct and adjust as required.

INSPECTION PERIOD (Accomplish based on operating hours or month, whichever is soonest.)	EVERY	6 WEEKS	3	6	12	MONTHS
	EVERY	250	500	1,000	2,000	HOURS

ENGINE

Basic components

1. Starting condition and unusual noise	I	←	←	←	←	←
2. Rotating condition during idling	M	←	←	←	←	←
3. Rotating condition during acceleration	M	←	←	←	←	←
4. Exhaust gas condition	I	←	←	←	←	←
5. Air cleaner element	C	←	←	←	←	←
6. Valve clearance	M*					M
7. Compression						M

Governor

8. Maximum no-load stabilized rotation speed	M	←	←	←	←	←
--	---	---	---	---	---	---

Lubrication system

9. Oil leakage	I	←	←	←	←	←
10. Oil level	I	←	←	←	←	←
11. Clogging and fouling of oil filter	I	←	←	←	←	←

Fuel system

12. Fuel leakage	I	←	←	←	←	←
13. Fouling and damage of fuel filter element	I	←	←	←	←	←
14. Injection timing				M	←	←
15. Injection nozzle injection pressure and condition						M

Cooling system

16. Radiator coolant level and leakage	I	←	←	←	←	←
17. Rubber hose deterioration	I	←	←	←	←	←
18. Radiator cap condition	I	←	←	←	←	←
19. Fan belt tension and damage	I	←	←	←	←	←

POWER TRANSMISSION SYSTEM

HST pump and motor

1. Oil leak	I	←	←	←	←	←
2. HST pump and motor operation, abnormal sound	I	←	←	←	←	←
3. HST charge pressure measurement		M	←	←	←	←

INSPECTION PERIOD (Accomplish based on operating hours or month, whichever is soonest.)	EVERY	6 WEEKS	3	6	12	MONTHS
	EVERY	250	500	1,000	2,000	HOURS
Reduction device unit						
4 Oil leak	I	←	←	←		
5 Oil level	I	←	←	←		
6 Reduction gear operation, abnormal sound	I	←	←	←		
7 Chain deformation and damage	I	←	←	←		
8 Chain bushing engaged portion deformation			I	←	←	
9 Sprocket deformation, damage			I	←	←	
RUNNING EQUIPMENT						
Wheels						
1 Tire air pressure	M	←	←	←		
2 Tire cuts, damage and uneven treads	I	←	←	←		
3 Loose hub bolts and hub nuts	T	←	←	←		
4 Tread depth	M	←	←	←		
5 Metal fragments, stones or other foreign objects in tires	I	←	←	←		
6 Rim, side ring and disc wheel damage	I	←	←	←		
7 Wheel bearing unusual noise and looseness	I	←	←	←		
Axle						
8 Deformation crack and damage					I	
STEERING SYSTEM						
Steering control lever						
1 Play and looseness	I	←	←	←		
2 Operating condition	I	←	←	←		
Link rod						
3 Bending and damage	I	←	←	←		
4 Installed portion looseness	I	←	←	←		
BRAKING SYSTEM						
Parking brake						
1 Braking effect	I	←	←	←		
MATERIALS HANDLING EQUIPMENT						
Bucket						
1 Bucket edge damage, wear	I	←	←	←		
2 Bucket deformation, damage and crack	I	←	←	←		
3 Bucket welded portion crack					I	
Lift arm and link						
4 Lift arm and link deformation, damage and crack	I	←	←	←		
5 Lift arm welded portion crack					I	

INSPECTION PERIOD (Accomplish based on operating hours or month, whichever is soonest.)	EVERY	6 WEEKS	3	6	12	MONTHS
	EVERY	250	500	1,000	2,000	HOURS
Bucket bracket						
6 Stop lever, link and pin damage	I	←	←	←		
7 Bucket bracket deformation, damage and crack	I	←	←	←		
8 Bucket bracket welded portion crack					I	
Various kinds of attachments						
9 Any abnormality and installed state of each part	I	←	←	←		
HYDRAULIC EQUIPMENT						
Cylinder						
1 Cylinder installed portion looseness	T	←	←	←		
2 Cylinder and piston rod damage	I	←	←	←		
3 Rising speed, dumping speed	I	←	←	←		
4 Cylinder operating condition, natural drop, natural forward tilt	M	←	←	←		
5 Cylinder oil leak	I	←	←	←		
6 Pin and cylinder bearing wear, damage	I	←	←	←		
Oil pump						
7 Oil leak, abnormal sound	I	←	←	←		
Hydraulic oil tank						
8 Oil amount and dirt	I	←	←	←		
9 Oil leak	I	←	←	←		
10 Tank and strainer	C	←	←	←		
Operating pedal						
11 Each connecting portion looseness	I	←	←	←		
12 Pedal function	I	←	←	←		
13 Pedal lock function	I	←	←	←		
Oil control valve						
14 Oil leakage	I	←	←	←		
15 Safety valve function	I	←	←	←		
16 Relief pressure measurement					M	
Hose piping						
17 Oil leak, looseness deformation damage	I	←	←	←		
ELECTRICAL EQUIPMENT						
Starter						
1 Pinion gear meshing	I	←	←	←		
Charger						
2 Charging function	I	←	←	←		
Electrical wiring						
3 Wire harness damage and connector looseness	I	←	←	←		
4 Fuses	I	←	←	←		

INSPECTION PERIOD (Accomplish based on operating hours or month, whichever is soonest.)	EVERY 6 WEEKS	3	6	12	MONTHS
	EVERY 250	500	1,000	2,000	HOURS

Preheater

5. Glow plug heat coil breakage			I	←	
6. Intake heater			I	←	

Battery

7. Specific gravity			M	←	
---------------------	--	--	---	---	--

SAFETY DEVICES AND OTHERS

Inter lock system

1. Operation and installed state	I	←	←	←	
----------------------------------	---	---	---	---	--

Operator guard and side guard

2. Installed portion looseness	T	←	←	←	
3. Deformation, crack, damage	I	←	←	←	

Direction indicator

4. Operation and installed state	I	←	←	←	
----------------------------------	---	---	---	---	--

Alarm unit

5. Operation and installed state	I	←	←	←	
----------------------------------	---	---	---	---	--

Lamp unit

6. Operation and installed state	I	←	←	←	
----------------------------------	---	---	---	---	--

Reverse alarm

7. Operation and installed state	I	←	←	←	
----------------------------------	---	---	---	---	--

Back mirror

8. Dirt and damage	I	←	←	←	
9. Back reflection state	I	←	←	←	

Instruments

10. Each instrument operation	I	←	←	←	
-------------------------------	---	---	---	---	--

Seat

11. Looseness, damage	I	←	←	←	
-----------------------	---	---	---	---	--

Seat belt

12. Slackness, damage	I	←	←	←	
-----------------------	---	---	---	---	--

Seat bar

13. Looseness, damage	I	←	←	←	
-----------------------	---	---	---	---	--

Body

14. Frame, cross member, etc. damage and cracking				I	
15. Bolt looseness				T	

Others

16. Each part grease up	L	←	←	←	
-------------------------	---	---	---	---	--

*: For new vehicle

Note:

In case of the hard operating condition, the service interval of 170 hours or 1 month may be recommendable.

SERVICE DATA

Adjustment value table

Item	Models	30-SSDK5	30-SSDK8	30-SSDK9	30-SSDK10	30-SSDK11	
Fan belt tension (10 kg (22 lb.) pressure applied)	mm (in)	8-13 (0.31-0.51)	←	←	←	←	
Fuel injection timing (BTDC) (Static)	deg	15	0 (Static)	←	←	←	
Fuel injection sequence		1-3-2-1	1-3-4-2	←	←	←	
Valve clearance (When warm)	mm (in)	IN.	0.15-0.25 (0.006-0.010)	0.18-0.22 (0.007-0.009)	0.15-0.25 (0.006-0.010)	←	
		EX.	0.15-0.25 (0.006-0.010)	0.33-0.37 (0.013-0.015)	0.31-0.41 (0.012-0.016)	←	
Idling speed	rpm	1300±50	750±50	←	←	←	
No load maximum speed	rpm	2600±50	←	2400±50	←	←	
Engine compression	MPa/rpm (psi/rpm)	Standard value	3.4/250 (493/250)	2.9/260 (412/260)	3.3/260 (469/260)	←	
		Limit	2.65/250 (384/250)	2.0/260 (284/260)	2.0/260 (284/260)	←	
Tire air pressure	kPa (kgf/cm ²)	27×8.50-15-4PR	260 (2.6)	←	←	←	←
		10-16.5-4PR	220 (2.2)	←	←	←	←
		10-16.5-6PR	325 (3.25)	←	←	←	←
		10-16.5-8PR	400 (4.0)	←	←	←	←
		12-16.5-4PR	350 (3.5)	←	←	←	←
		5.50-15-8PR	700 (7.0)	←	←	←	←
Oil control valve set pressure	psi (kgf/cm ²)	Main relief	160 (15.7)	170 (16.7)	←	←	
		Pon relief	110 (10.8)	100 (9.8)	←	←	
Hub nut tightening torque	N·m (kg·m) (ft·lb)	117.6-147.0 (12-15) [87-108]	←	←	←	←	
Operator guard mounting bolt tightening torque	N·m (kg·m) (ft·lb)	25.9-60.4 (2.64-6.16) [19.1-44.6]	←	←	←	←	
Battery fluid specific gravity 20°C		1.280	←	←	←	←	

En

Lubricant capacities and types

Item	Models	30-SSDK5	30-SSDK8	30-SSDK9	30-SSDK10	30-SSDK11	Type	
Engine oil	ℓ (US gal)	5.4 (1.426)	7.3 (1.927)	←	9.0 (2.376)	←	API classification over CF-4 SAE 10W-30	
Oil tank	ℓ (US gal)	19 (5.0)	30 (7.9)	←	35 (9.2)	←	E/G oil SW-30	
Chain case	ℓ (US gal)	15.5 (4.1)	20 (5.28)	←	←	←	API classification over CC SAE 10W-30	
Lubrication points	ℓ (US gal)	Proper amount	←	←	←	←	MP Grease	
Fuel tank	ℓ (US gal)	35 (9.2)	85 (22.4)	←	←	←		
Engine cooling system	ℓ (US gal)	STD	5.2 (1.37)	7.1 (1.87)	7.8 (2.06)	9.3 (2.46)	←	LLC* (30%)
		OPT (Cold area)						LLC* (50%)

* LLC = Long Life Coolant (Appropriately diluted with fresh water)

WHEEL & TIRE

Model	Type	Tire size	Rim size
30-SSDK5	STD	Pneumatic tire (with tube)	27×8.50-15-4PR
	OPT	Non-punc tire	5.50-15
30-SSDK8	STD	Pneumatic tire (tubeless)	10×16.5-6PR
		Pneumatic tire (tubeless)	10×16.5-6PR
	OPT	Flotation tire (tubeless)	12×16.5-8PR
		Non-punc tire	7.00-15
30-SSDK9	STD	Pneumatic tire (tubeless)	10×16.5-6PR
		Pneumatic tire (tubeless)	10×16.5-6PR
	OPT	Flotation tire (tubeless)	12×16.5-8PR
		Non-punc tire	7.00-15
30-SSDK10	STD	Pneumatic tire (tubeless)	10×16.5-6PR
		Pneumatic tire (tubeless)	12×16.5-8PR
	OPT	Flotation tire (tubeless)	12×16.5-8PR
		Non-punc tire	7.00-15
30-SSDK11	STD	Pneumatic tire (tubeless)	10×16.5-6PR
		Pneumatic tire (tubeless)	12×16.5-8PR
	OPT	Flotation tire (tubeless)	12×16.5-8PR
		Non-punc tire	7.00-15

VEHICLE DIMENSIONS

30-5SDK5 · 8 · 9

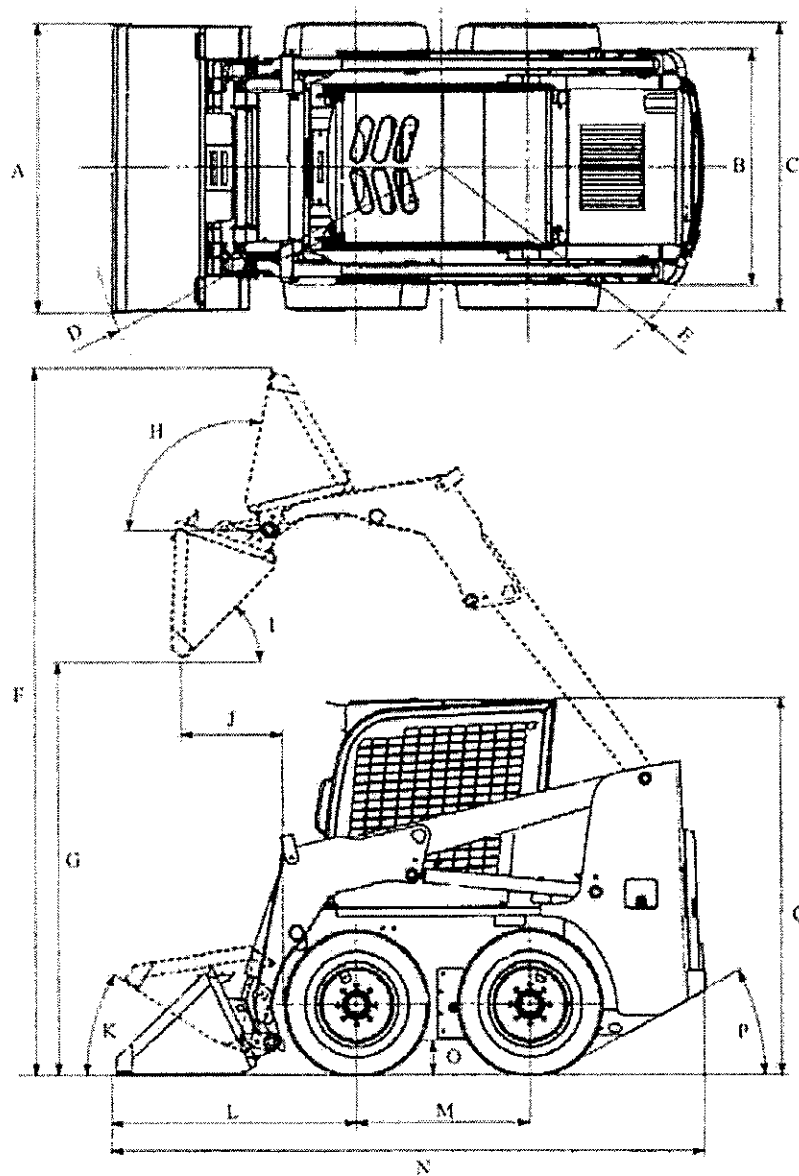

	30-5SDK5	30-5SDK8	30-5SDK9
A (mm)	1230	1530	←
B (mm)	970	1250	←
C (mm)	1180	1520	1525
D (mm)	1700	1890	1930
E (mm)	1310	1410	1460
F (mm)	3645	3690	3800
G (mm)	2120	2190	2290
H (deg)	102	←	←
I (deg)	40	45	←
J (mm)	490	510	450
K (deg)	34	←	←
L (mm)	1180	1265	←
M (mm)	815	915	1020
N (mm)	2875	3095	3200
O (mm)	160	180	←
P (% ton (t))	47	55	←
Q (mm)	1860	1945	←

En

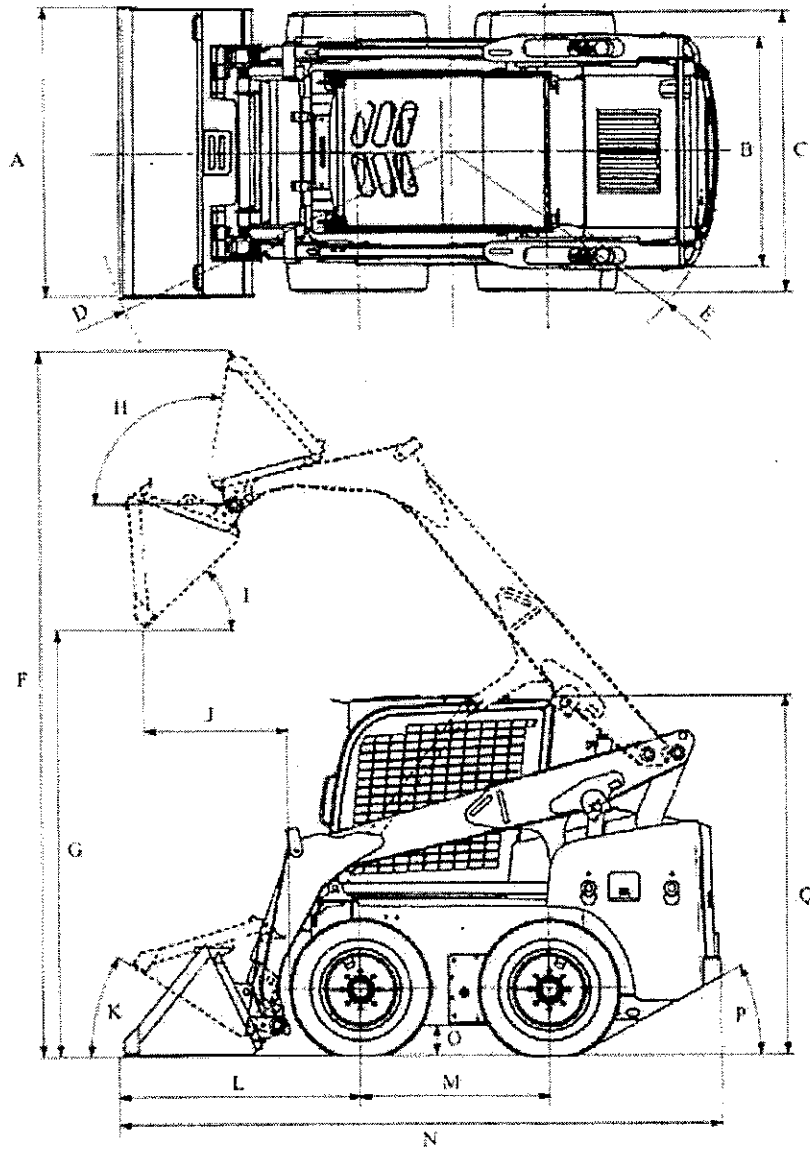

	30-5SDK10	30-5SDK11
A (mm)	1530	←
B (mm)	1250	←
C (mm)	1525	←
D (mm)	1960	↑
E (mm)	1460	↑
F (mm)	3870	↑
G (mm)	2330	↑
H (deg)	100	↑
I (deg)	45	↑
J (mm)	760	↑
K (deg)	34	↑
L (mm)	1295	↑
M (mm)	1020	↑
N (mm)	3235	↑
O (mm)	180	↑
P (% tan α)	55	↑
Q (mm)	1950	↑

